

Mounting Considerations For Power Semiconductors

AN1040/D

Prepared by: Bill Roehr

INTRODUCTION

Current and power ratings of semiconductors are inseparably linked to their thermal environment. Except for lead-mounted parts used at low currents, a heat exchanger is required to prevent the junction temperature from exceeding its rated limit, thereby running the risk of a high failure rate. Furthermore, the semiconductor industry's field history indicated that the failure rate of most silicon semiconductors decreases approximately by one-half for a decrease in junction temperature from 160°C to 135°C.⁽¹⁾ Guidelines for designers of military power supplies impose a 110°C limit upon junction temperature.⁽²⁾ Proper mounting minimizes the temperature gradient between the semiconductor case and the heat exchanger.

Most early life field failures of power semiconductors can be traced to faulty mounting procedures. With metal packaged devices, faulty mounting generally causes unnecessarily high junction temperature, resulting in reduced component lifetime, although mechanical damage has occurred on occasion from improperly mounting to a warped surface. With the widespread use of various plastic-packaged semiconductors, the prospect of mechanical damage is very significant. Mechanical damage can impair the case moisture resistance or crack the semiconductor die.

In this note, mounting procedures are discussed in general terms for several generic classes of packages. As newer packages are developed, it is probable that they will fit into the generic classes discussed in this note. Unique requirements are given on data sheets pertaining to the particular package. The following classes are defined:

- Stud Mount
- Flange Mount
- Pressfit
- Plastic Body Mount
- Tab Mount
- Surface Mount

Appendix A contains a brief review of thermal resistance concepts. Appendix B discusses measurement difficulties with interface thermal resistance tests. Appendix C indicates the type of accessories supplied by a number of manufacturers.

MOUNTING SURFACE PREPARATION

In general, the heatsink mounting surface should have a flatness and finish comparable to that of the semiconductor package. In lower power applications, the heatsink surface is satisfactory if it appears flat against a straight edge and is free from deep scratches. In high-power applications, a more detailed examination of the surface is required. Mounting holes and surface treatment must also be considered.

Surface Flatness

Surface flatness is determined by comparing the variance in height (Δh) of the test specimen to that of a reference standard as indicated in Figure 2. Flatness is normally specified as a fraction of the Total Indicator Reading (TIR). The mounting surface flatness, i.e., $\Delta h/TIR$, if less than

AN1040/D

Data showing the effect of compounds on several package types under different mounting conditions is shown in Table 1. The rougher the surface, the more valuable the grease becomes in lowering contact resistance; therefore, when mica insulating washers are used, use of grease is generally mandatory. The joint compound also improves the breakdown rating of the insulator.

Conductive Pads

Because of the difficulty of assembly using grease and the evaporation problem, some equipment manufacturers will not, or cannot, use grease. To minimize the need for grease, several vendors offer dry conductive pads which approximate performance obtained with grease. Data for a

greased bare joint and a joint using Grafoil®, a dry graphite compound, is shown in the data of Figure 3 through Figure 6. Grafoil is claimed to be a replacement for grease when no electrical isolation is required; the data indicates it does indeed perform as well as grease. Another conductive pad available from Aavid is called Kon-Dux™. It is made with a unique, grain oriented, flake-like structure (patent pending). Highly compressible, it becomes formed to the surface roughness of both the heatsink and semiconductor. Manufacturer's data shows it to provide an interface thermal resistance better than a metal interface with filled silicone grease. Similar dry conductive pads are available from other manufacturers. They are a fairly recent development; long term problems, if they exist, have not yet become evident.

Table 1. Approximate Values for Interface Thermal Resistance Data from Measurements Performed in onsemi Applications Engineering Laboratory

Dry interface values are subject to wide variation because of extreme dependence upon surface conditions. Unless otherwise noted, the case temperature is monitored by a thermocouple located directly under the die reached through a hole in the heatsink. (See Appendix B for a discussion of Interface Thermal Resistance Measurements.)

Package Type and Data		Interface Thermal Resistance (°C/W)						See Note
		Test Torque In Lb	Metal to Metal		With Insulator		Type	
JEDEC Outlines	Description			Dry	Lubed	Dry		Lubed
DO-203AA, TO-210AA TO-208AB	10-32 Stud 7/16" Hex	15	0.3	0.2	1.6	0.8	3 mil Mica	
DO-203AB, TO-210AC TO-208	1/4-28 Stud 11/16" Hex	25	0.2	0.1	0.8	0.6	5 mil Mica	
DO-208AA	Pressfit, 1/2"	-	0.15	0.1	-	-	-	
TO-204AA (TO-3)	Diamond Flange	6	0.5	0.1	1.3	0.36	3 mil Mica	1
TO-213AA (TO-66)	Diamond Flange	6	1.5	0.5	2.3	0.9	2 mil Mica	
TO-126	Thermopad 1/4" x 3/8"	6	2.0	1.3	4.3	3.3	2 mil Mica	
TO-220AB	Thermowatt	8	1.2	1.0	3.4	1.6	2 mil Mica	1, 2

NOTES: 1. See Figure 3 through Figure 7 for additional data on TO-3 and TO-220 packages.
2. Screw not insulated. See Figure 20.

INSULATION CONSIDERATIONS

Since most power semiconductors use vertical device construction, it is common to manufacture power semiconductors with the output electrode (anode, collector or drain) electrically common to the case; the problem of isolating this terminal from ground is a common one. For lowest overall thermal resistance, which is quite important when high power must be dissipated, it is best to isolate the entire heatsink/semiconductor structure from ground, rather than to use an insulator between the semiconductor and the heatsink. Heatsink isolation is not always possible, however, because of EMI requirements, safety reasons, instances where a chassis serves as a heatsink or where a heatsink is common to several non-isolated packages. In

these situations, insulators are used to isolate the individual components from the heatsink. Newer packages, such as the **onsemi FULLPAK™** and EMS modules, contain the electrical isolation material within, thereby saving the equipment manufacturer the burden of addressing the isolation problem.

Insulator Thermal Resistance

When an insulator is used, thermal grease is of greater importance than with a metal-to-metal contact, because two interfaces exist instead of one and some materials, such as mica, have a hard, markedly uneven surface. With many isolation materials, reduction of interface thermal resistance

Data obtained by Thermalloy, showing interface highly toxic.) Thermafilm is a filled polyimide material resistance for different insulators and torques applied to which is used for isolation (variation of Kapton). It is a TO-18 (TO-18) and TO-18 packages, are shown in popular material for low power applications because of its Figure 3 through Figure 6, for bare and greased surfaces low cost ability to withstand high temperatures, and ease of Similar materials to those shown are available from several handling in contrast to mica which chips and flakes easily. manufacturers. It is obvious that with some arrangements, A number of other insulating materials are also shown. the interface thermal resistance exceeds that of the They cover a wide range of insulation resistance, thermal semiconductor (junction to case). resistance and ease of handling. Mica has been widely used

Referring to Figure 3 through Figure 6, one may in the past because it offers high breakdown voltage and conclude that when high power is handled, beryllium oxide fairly low thermal resistance at a low cost, but it certainly is unquestionably the best. However, it is an expensive should be used with grease. choice. (It should not be cut or abraded, as the dust is

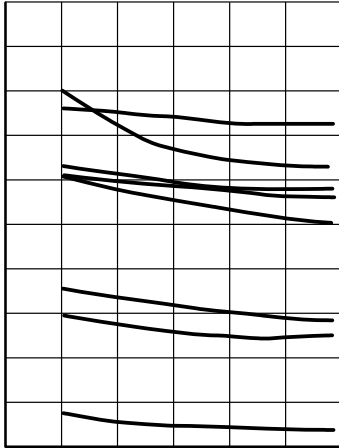

Silicone rubber insulators have gained favor because they are somewhat conformal under pressure. Their ability to fill in most of the metal voids at the interface reduces the need for thermal grease. When first introduced, they suffered from cut-through after a few years in service. The ones presently available have solved this problem by having imbedded pads of Kapton or fiberglass. By comparing Figure 5 and Figure 6, it can be noted that Thermasil™, a filled silicone rubber, without grease, has about the same interface thermal resistance as greased mica for the TO-220 package.

A number of manufacturers offer silicone rubber insulators. Table 2 shows measured performance of a number of these insulators under carefully controlled, nearly identical conditions. The interface thermal resistance extremes are over 2:1 for the various materials. It is also clear that some of the insulators are much more tolerant than others of out-of-flat surfaces. Since the tests were performed, newer products have been introduced. The Bergquist K-10® pad, for example, is described as having about 2/3 the interface resistance of the Sil-Pad® 1000 which would place its performance close to the Chomerics 1671 pad. Aavid also offers an isolated pad called Rubber-Duc™, however, it is only available vulcanized to a heatsink and, therefore, was not included in the comparison. Published data from Aavid shows $R_{\theta CS}$ below 0.3°C/W for pressures above 500 psi. However, surface flatness and other details are not specified, so a comparison cannot be made with other data in this note.

Table 2. Thermal Resistance of Silicone Rubber Pads

Manufacturer

**Table 3. Performance of Silicon Rubber Insulators
Tested Per MIL I 49456**

Material	Measured Thermal Resistance (°C/W)	
	Thermalloy Data ⁽¹⁾	Bergquist Data ⁽²⁾
Bare Joint, greased	0.033	0.008
BeO, greased	0.082	–
CHO–THERM, 1617	0.233	–
Q Pad (non–insulated)	–	0.009
Sil–Pad, K–10	0.263	0.200
Thermasil III	0.267	–
Mica, greased	0.329	0.400
Sil–Pad 1000	0.400	0.300
CHO–THERM 1674	0.433	–
Thermasil II	0.500	–
Sil–Pad 400	0.533	0.440
Sil–Pad K–4	0.583	0.440

(1) From Thermalloy EIR 87–1030

(2) From Bergquist Data Sheet

Insulation Resistance

When using insulators, care must be taken to keep the matting surfaces clean. Small particles of foreign matter can puncture the insulation, rendering it useless or seriously lowering its dielectric strength. In addition, particularly when voltages higher than 300 V are encountered, problems with creepage may occur. Dust and other foreign material can shorten creepage distances significantly; so having a clean assembly area is important. Surface roughness and humidity also lower insulation resistance. Use of thermal grease usually raises the withstand voltage of the insulation system, but excess must be removed to avoid collecting dust. Because of these factors, which are not amenable to analysis, hi–pot testing should be done on prototypes and a large margin of safety employed.

Insulated Electrode Packages

Because of the nuisance of handling and installing the accessories needed for an insulated semiconductor mounting, equipment manufacturers have longed for cost–effective insulated packages since the 1950's. The first to appear were stud mount types which usually have a layer of beryllium oxide between the stud hex and the can. Although effective, the assembly is costly and requires manual mounting and lead wire soldering to terminals on top of the case. In the late 80's, a number of electrically isolated parts became available from various semiconductor manufacturers. These offerings presently consist of multiple chips and integrated circuits as well as the more conventional single chip devices.

The newer insulated packages can be grouped into two categories. The first has insulation between the semiconductor chips and the mounting base; an exposed area of the mounting base is used to secure the part. The Energy Management Series (EMS) modules, shown in Figure 16, Case 806 (ICePAK™) and Case 388A (TO–258AA) (see Figure 16) are examples of parts in this category. The second category contains parts which have a plastic overmold covering the metal mounting base. The isolated, Case 221C, illustrated in 21, is an example of parts in the second category.

Parts in the first category (those with an exposed metal flange or tab) are mounted the same as their non–insulated

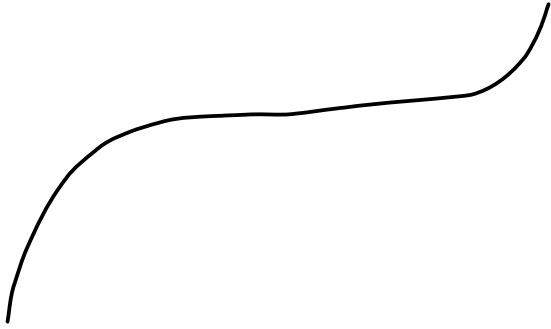

FASTENING TECHNIQUES

Each of the various classes of packages in use requires different fastening techniques. Details pertaining to each type are discussed in the following sections. Some general considerations follow.

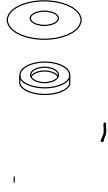

The copper flange of the Energy Management Series (EMS) modules is very thick. Consequently, the parts are rugged and indestructible for all practical purposes. No special precautions are necessary when fastening these parts to a heatsink.

Some packages specify a tightening procedure. For example, with the Power Tap package, 15, final torque should be applied first to the center position.

The RF power modules (MHW series) are more sensitive to the flatness of the heatsink than other packages because

a ceramic (BeO) substrate is attached to a relatively thin, fairly long, flange. The maximum allowable flange bending to avoid mechanical damage has been determined and presented in detail in Engineering Bulletin EB107/D, "Mounting Considerations for onsemi RF Power Modules." Many of the parts can handle a combined heatsink and flange deviation from flat of 7 to 8 mils which is commonly available. Others must be held to 1.5 mils, which requires that the heatsink have nearly perfect flatness.

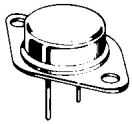

CASE 1, 11
TO 204AA
(TO 3)

CASE 383

Figure 14. TO 3 Variations

CASE 357C

Figure 15. Plastic Power Tap

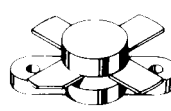

CASE 211

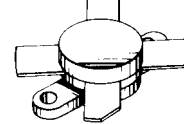

CASE 211

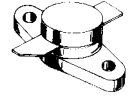

CASE 215

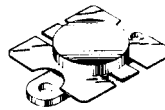

CASE 316

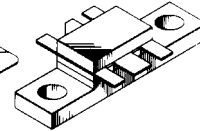

CASE 319
(CS 12)

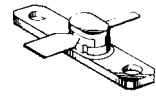

CASE 328A

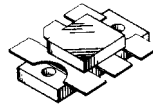

CASE 333

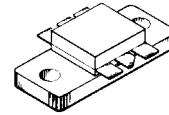

CASE 333A
(MAAC PAC)

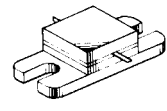

CASE 336

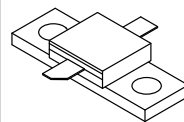

CASE 337

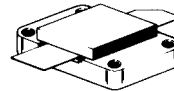

CASE 368
(HOG PAC)

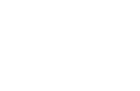

CASE 744A

Figure 17. RF Stripline Isolated Output Opposed Emitter (SOE) Series



CASE 373

CASE 807

CASE 807A

CASE 808

CASE 809

CASE 812

CASE 813

CASE 814B

CASE 816

CASE 819

Figure 16. Energy Management Series (Isolated Base Plate)

A LARGE ARRAY OF PARTS FIT INTO THE FLANGE MOUNT CLASSIFICATION

AN1040/D

sufficient torque, the thermal compound will squeeze out of the mounting hole areas, but will remain under the center of the flange, deforming it. Deformations of 2 – 3 mils have been measured between the center and the ends under such conditions (enough to crack internal ceramic).

also be effectively mounted with clips as shown in Figure 27.

To obtain high pressure without cracking the case, a pressure spreader bar should be used under the clip. Interface thermal resistance with the cantilever beam or clips can be lower than with screw mounting.

The ICePAK (Case 806-05) is basically an elongated TO-220 package with isolated chips. The mounting precautions for the TO-220 consequently apply. In addition, since two mounting screws are required, the alternate tightening procedure described for the flange mount package should be used.

In situations where a tab mount package is making direct contact with the heatsink, an eyelet may be used, provided sharp blows or impact shock is avoided.

- a) Preferred Arrangement for Isolated or Non isolated Mounting. Screw is at Semiconductor Case Potential. 6 32 Hardware is Used. Choose from Parts Listed Below
- b) Alternate Arrangement for Isolated Mounting when Screw must be at Heatsink Potential. 4 40 Hardware is Used. Use Parts Listed Below

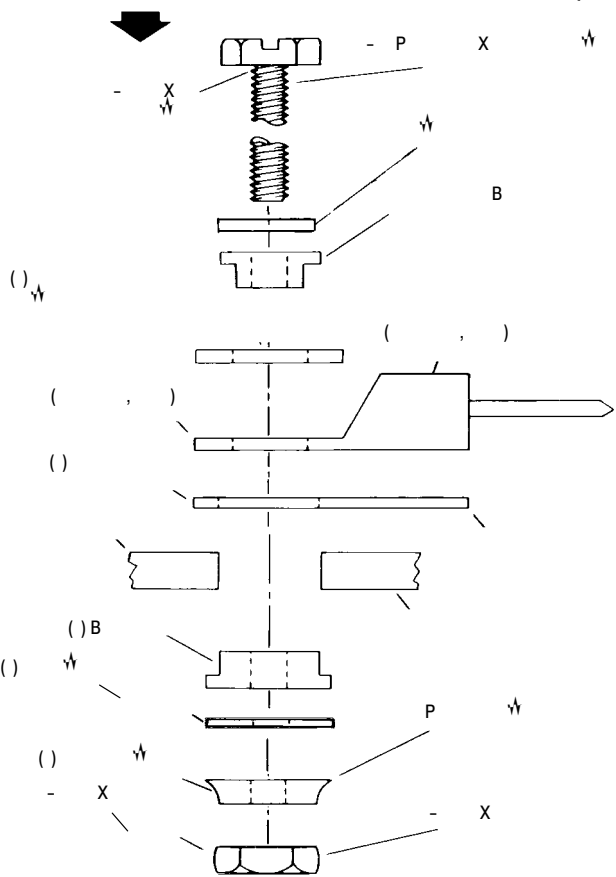

- (1) Used with thin chassis and/or large hole.
- (2) Used when isolation is required.
- (3) Required when nylon bushing is used.

Figure 20. Mounting Arrangements for Tab Mount TO 220

Plastic Body Mount

The Thermopad™ and isolated plastic power packages shown in Figure 21 are typical of packages in this group. They have been designed to feature minimum size with no compromise in thermal resistance. For the Thermopad (Case 77) parts, this is accomplished by die-bonding the silicon chip on one side of a thin copper sheet; the opposite side is exposed as a mounting surface. The copper sheet has a hole for mounting; plastic is molded enveloping the chip but leaving the mounting hole open. The low thermal resistance of this construction is obtained at the expense of a requirement that strict attention be paid to the mounting procedure.

The isolated (Case 221C-02) is similar to a TO-220 except that the tab is encased in plastic. Because the mounting force is applied to plastic, the mounting procedure differs from a standard TO-220 and is similar to that of the Thermopad.



CASE 77
TO 225AA/TO 126
(THERMOPAD)

CASE 221C 02
(FULLY ISOLATED)

CASE 221D 02
(FULLY ISOLATED)

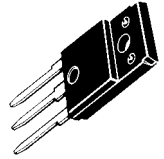

CASE 340B 03
(FULLY ISOLATED)

Figure 21. Plastic Body Mount Packages

Several types of fasteners may be used to secure these packages; machine screws, eyelets, or clips are preferred. With screws or eyelets, a conical washer should be used which applies the proper force to the package over a fairly wide range of deflection and distributes the force over a fairly large surface area. Screws should not be tightened with any type of air-driven torque gun or equipment which may cause high impact. Characteristics of a suitable conical washer is shown in Figure 8.

Figure 22 through Figure 24 shows details of mounting Case 77 devices. Clip mounting is fast and requires minimum hardware, however, the clip must be properly chosen to insure that the proper mounting force is applied. When electrical isolation is required with screw mounting, a bushing inside the mounting hole will insure that the screw threads do not contact the metal base.

The isolated, (Case 221C, 221D, and 340B) permits the mounting procedure to be greatly simplified over that of a standard TO-220. As shown in Figure 27, one properly chosen clip, inserted into two slotted holes in the heatsink, is all the hardware needed. Even though clip pressure is much lower than obtained with a screw, the thermal

resistance is about the same for either method. This occurs because the clip bears directly on top of the die and holds the package flat while the screw causes the package to lift up somewhat under the die. (See Figure 36 of Appendix B.) The interface should consist of a layer of thermal grease or a highly conductive thermal pad. Of course, screw mounting shown in Figure 26 may also be used, but a conical compression washer should be included. Both methods afford a major reduction in hardware as compared to the conventional mounting method with a TO-220 package which is shown in Figure 25.

Surface Mount

Although many of the tab mount parts have been surface mounted, special small footprint packages for mounting power semiconductors using surface mount assembly techniques have been developed. The DPAK, shown in Figure 28, for example, will accommodate a die up to 112 mils x 112 mils, and has a typical thermal resistance around 2°C/W junction to case. The thermal resistance values of the solder interface is well under 1°C/W. The printed circuit board also serves as the heatsink.

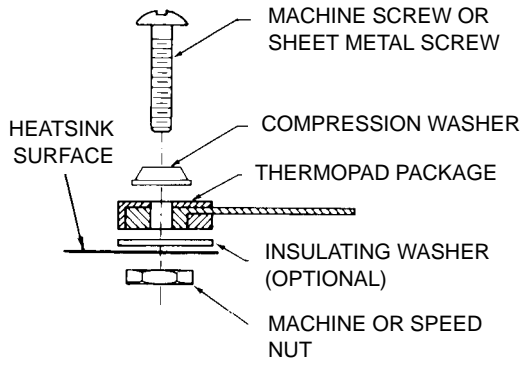

Figure 22. Machine Screw Mounting

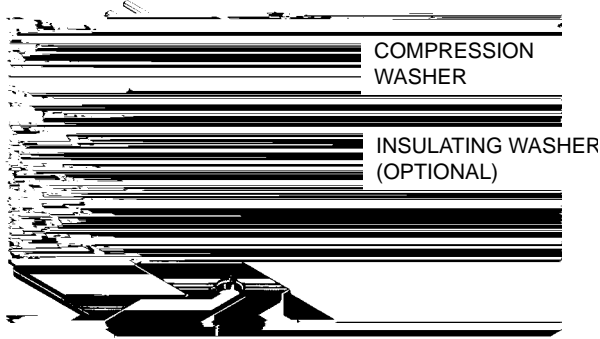
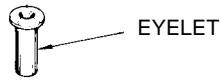

Figure 23. Eyelet Mounting

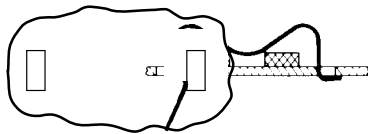
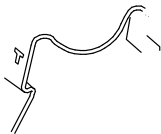

Figure 24. Clips

dimension become larger; this may result in device failure as power is applied.

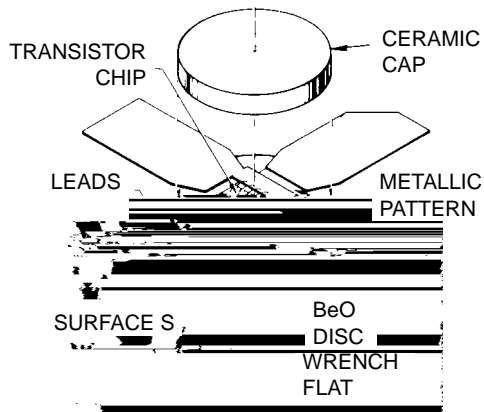
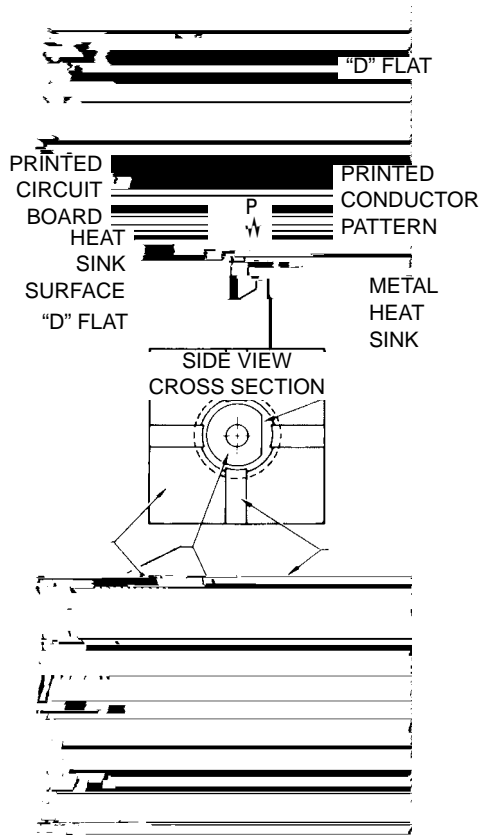

Figure 32. Component Parts of a Stud Mount



**APPENDIX A
THERMAL RESISTANCE CONCEPTS**

The basic equation for heat transfer under steady-state conditions is generally written as:

$$q = hA\Delta T \quad (1)$$

where q = rate of heat transfer or power dissipation (P_D)
 h = heat transfer coefficient,
 A = area involved in heat transfer,
 ΔT = temperature difference between regions of heat transfer.

However, electrical engineers generally find it easier to work in terms of thermal resistance, defined as the ratio of temperature to power. From Equation 1, thermal resistance, R_θ , is

$$R_\theta = \Delta T/q = 1/hA \quad (2)$$

The coefficient (h) depends upon the heat transfer mechanism used and various factors involved in that particular mechanism.

An analogy between Equation (2) and Ohm's Law is often made to form models of heat flow. Note that T could be thought of as a voltage thermal resistance corresponds to electrical resistance (R); and, power (q) is analogous to current (I). This gives rise to a basic thermal resistance model for a semiconductor as indicated by Figure 35.

The equivalent electrical circuit may be analyzed by using Kirchoff's Law and the following equation results:

$$T_J = P$$

APPENDIX B MEASUREMENT OF INTERFACE THERMAL RESISTANCE

Measuring the interface thermal resistance $R_{\theta CS}$ appears deceptively simple. All that's apparently needed is a thermocouple on the semiconductor case, a thermocouple on the heatsink, and a means of applying and measuring DC power. However, $R_{\theta CS}$ is proportional to the amount of contact area between the surfaces and consequently is affected by surface flatness and finish and the amount of pressure on the surfaces. The fastening method may also be a factor. In addition, placement of the thermocouples can have a significant influence upon the results. Consequently, values for interface thermal resistance presented by different manufacturers are not in good agreement. Fastening methods and thermocouple locations are considered in this Appendix.

When fastening the test package in place with screws, thermal conduction may take place through the screws, for example, from the flange ear on a TO-3 package directly to the heatsink. This shunt path yields values which are artificially low for the insulation material and dependent upon screw head contact area and screw material. MIL-I-49456 allows screws to be used in tests for interface thermal resistance probably because it can be argued that this is "application oriented."

Thermalloy takes pains to insulate all possible shunt conduction paths in order to more accurately evaluate insulation materials. The **onsemi** fixture uses an insulated clamp arrangement to secure the package which also does not provide a conduction path.

As described previously, some packages, such as a TO-220, may be mounted with either a screw through the tab or a clip bearing on the plastic body. These two methods often yield different values for interface thermal resistance. Another discrepancy can occur if the top of the package is exposed to the ambient air where radiation and convection can take place. To avoid this, the package should be covered with insulating foam. It has been estimated that a 15 to 20% error in $R_{\theta CS}$ can be incurred from this source.

Another significant cause for measurement discrepancies is the placement of the thermocouple to

ratings are supposed to be based on this reference point. Unfortunately, the placement of the thermocouple is tedious and leaves the semiconductor in a condition unfit for sale.

The **onsemi**

AN1040/D

PACKAGE INDEX

PREFACE

When the JEDEC registration system for package outlines started in 1957, numbers were assigned sequentially whenever manufacturers wished to establish a package as an industry standard. As minor variations developed from these industry standards, either a new, non-related number was issued by JEDEC or manufacturers would attempt to relate the part to an industry standard via some appended description.

In an attempt to ease confusion, JEDEC established the present system in late 1968 in which new packages are assigned into a category, based on their general physical appearance. Differences between specific packages in a

category are denoted by suffix letters. The older package designations were re-registered to the new system as time permitted.

For example the venerable TO-3 has many variations. Can heights differ and it is available with 30, 40, 50, and 60 mil pins, with and without lugs. It is now classified in the TO-204 family. The TO-204AA conforms to the original outline for the TO-3 having 40 mil pins while the TO-204AE has 60 mil pins, for example.

The new numbers for the old parts really haven't caught on very well. It seems that the DO-4, DO-5 and TO-3 still convey sufficient meaning for general verbal communication.

ON Case Number	JEDEC Outline		Notes	Mounting Class
	Original System	Revised System		
001	TO-3	TO-204AA		Flange
003	TO-3		2	Flange
009	TO-61	TO-210AC		Stud
011	TO-3	TO-204AA	-	Flange
011A	TO-3	-	2	Flange
012	TO-3	-	2	Flange
036	TO-60	TO-210AB	-	Stud
042A	DO-5	DO-203AB	-	Stud
044	DO-4	DO-203AA	-	Stud
054	TO-3	-	2	Flange
056	DO-4	-	-	Stud
058	DO-5	-	2	Stud
61-04				Flange
63-02	TO-64	TO-208AB		Stud
63-03	TO-64	TO-2088AB		Stud
077	TO-126	TO-225AA	-	Plastic
080	TO-66	TO-213AA	-	Flange
086	-	TO-208	1	Stud
086L	-	TO-298	1	Stud
144B-05				Stud
145A-09				Stud
145A-10				Stud
145C	TO-232		1	Stud
157	-	DO-203	1	Stud
160-03	TO-59	TO-210AA	-	Stud
167	-	DO-203	1	Stud
174-04				Pressfit

Notes: 1. Would fit within this family outline if registered with JEDEC.
2. Not within all JEDEC dimensions.

ON Case Number	JEDEC Outline		Notes	Mounting Class
	Original System	Revised System		
175-03				Stud
197	-	TO-204AE	-	Flange
211-07				Flange
211-11				Flange
215-02				Flange
221	-	TO-220AB	-	Tab
221C-02				Plastic
221D-02	-	-	Isolated TO-220	Plastic
235	-	TO-208	1	Stud
235-03				Stud
238	-	TO-208	1	Stud
239	-	TO-208	-	Stud
244-04				Stud
245	DO-4	-	-	Stud
257-01	DO-5	-	-	Stud
263	-	TO-208	-	Stud
263-04				Stud
283	DO-4	-	-	Stud
289	-	TO-209	1	Stud
305-01				Stud
310-02				Pressfit
311-02			Isolated	Stud
311-02				Pressfit
311-02				Stud
314B-03				Tab

ON Case Number	JEDEC Outline		Notes	Mounting Class
	Original System	Revised System		
314D-03				Tab
316-01				Flange
319-06				Flange
328A-03				Flange
332-04				Stud
333-04				Flange
333A-02				Flange
336-03				Flange
337-02				Flange
340		TO-218AC		Tab
340A-02				Plastic
340B-03			Isolated TO-218	Plastic
342-01				Flange
357B-01				Flange
361-01				Flange
368-02				Flange
369-06		TO-251		Insertion
369A-12		TO-252		Surface
373-01			Isolated	Flange
383-01			Isolated	Flange
387-01		TO-254AA	Isolated 2	Tab
388A-01		TO-258AA	Isolated 2	Tab
744-02				Flange
744A-01				Flange
043-07	DO-21	DO-208AA		Pressfit

- (1) MIL-HANDBOOK - 2178, SECTION 2.2.
- (2) "Navy Power Supply Reliability - Design and Manufacturing Guidelines" NAVMAT P4855-1, Dec. 1982 NAVPUBFORCEN, 5801 Tabor Ave., Philadelphia, PA 19120.
- (3) Catalog #87-HS-9, (1987), page 8, Thermalloy, Inc., P.O. Box 810839, Dallas, Texas 75381-0839.
- (4) ITW Shakeproof, St. Charles Road, Elgin, IL 60120.
- (5) Robert Batson, Elliot Fraunglass and James P Moran, "Heat

onsemi, and other names, marks, and brands are registered and/or common law trademarks of Semiconductor Components Industries, LLC dba "**onsemi**" or its affiliates and/or subsidiaries in the United States and/or other countries. **onsemi** owns the rights to a number of patents, trademarks, copyrights, trade secrets, and other intellectual property. A listing of **onsemi**'s product/patent coverage may be accessed at www.onsemi.com/site/pdf/Patent-Marking.pdf. **onsemi** reserves the right to make changes at any time to any products or information herein, without notice. The information herein is provided "as-is" and **onsemi** makes no warranty, representation or guarantee regarding the accuracy of the information, product features, availability, functionality, or suitability of its products for any particular purpose, nor does **onsemi** assume any liability arising out of the application or use of any product or circuit, and specifically disclaims any and all liability, including without limitation special, consequential or incidental damages. Buyer is responsible for its products and applications using **onsemi** products, including compliance with all laws, regulations and safety requirements or standards, regardless of any support or applications information provided by **onsemi**. "Typical" parameters which may be provided in **onsemi** data sheets and/or specifications can and do vary in different applications and actual performance may vary over time. All operating parameters, including "Typicals" must be validated for each customer application by customer's technical experts. **onsemi** does not convey any license under any of its intellectual property rights nor the rights of others. **onsemi** products are not designed, intended, or authorized for use as a critical component in life support systems or any FDA Class 3 medical devices or medical devices with a same or similar classification in a foreign jurisdiction or any devices intended for implantation in the human body. Should