



**1N5820, 1N5821, 1N5822**

## 1N5820, 1N5821, 1N5822

### NOTE 3 — DETERMINING MAXIMUM RATINGS

Reverse power dissipation and the possibility of thermal runaway

**1N5820, 1N5821, 1N5822**

**1N5820, 1N5821, 1N5822**

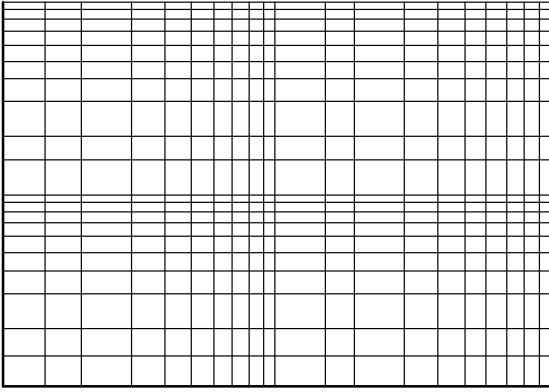



# 1N5820, 1N5821, 1N5822

## ORDERING INFORMATION

Device	Package	Shipping†
1N5820	Axial Lead	500 Units/Bag
1N5820G	Axial Lead (Pb-Free)	500 Units/Bag
1N5820RL	Axial Lead	1500/Tape & Reel
1N5820RLG	Axial Lead (Pb-Free)	1500/Tape & Reel
1N5821	Axial Lead	500 Units/Bag
1N5821G	Axial Lead (Pb-Free)	500 Units/Bag
1N5821RL	Axial Lead	1500/Tape & Reel
1N5821RLG	Axial Lead (Pb-Free)	1500/Tape & Reel
1N5822	Axial Lead	500 Units/Bag
1N5822G	Axial Lead (Pb-Free)	500 Units/Bag
1N5822RL	Axial Lead	1500/Tape & Reel
1N5822RLG	Axial Lead (Pb-Free)	1500/Tape & Reel

†For information on tape and reel specifications, including part orientation and tape sizes, please refer to our Tape and Reel Packaging Specifications Brochure, BRD8011/D.

**AXIAL LEAD**  
CASE 267-05  
ISSUE G

DATE 06 JUN 2000

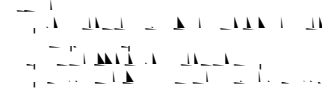
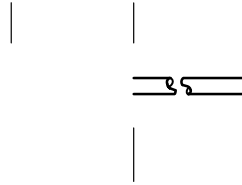
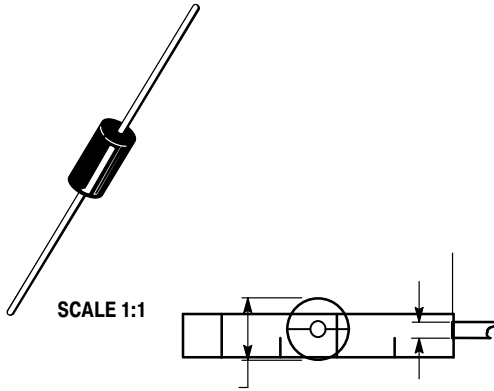

DIM	INCHES		MILLIMETERS	
	MIN	MAX	MIN	MAX
A				
B				
D				
K				

<b>DOCUMENT NUMBER:</b>	<b>98ASB42170B</b>	Electronic versions are uncontrolled except when accessed directly from the Document Repository. Printed versions are uncontrolled except when stamped "CONTROLLED COPY" in red.
<b>DESCRIPTION:</b>	<b>AXIAL LEAD</b>	<b>PAGE 1 OF 1</b>

**onsemi** and **ONSEMI** are trademarks of Semiconductor Components Industries, LLC dba **onsemi** or its subsidiaries in the United States and/or other countries. **onsemi** reserves the right to make changes without further notice to any products herein. **onsemi** makes no warranty, representation or guarantee regarding the suitability of its products for any particular purpose, nor does **onsemi** assume any liability arising out of the application or use of any product or circuit, and specifically disclaims any and all liability, including without limitation special, consequential or incidental damages. **onsemi** does not convey any license under its patent rights nor the rights of others.



**onsemi**, **onsemi**, and other names, marks, and brands are registered and/or common law trademarks of Semiconductor Components Industries, LLC dba "**onsemi**" or its affiliates and/or subsidiaries in the United States and/or other countries. **onsemi** owns the rights to a number of patents, trademarks, copyrights, trade secrets, and other intellectual property. A listing of **onsemi**'s product/patent coverage may be accessed at [www.onsemi.com/site/pdf/Patent-Marking.pdf](http://www.onsemi.com/site/pdf/Patent-Marking.pdf). **onsemi** reserves the right to make changes at any time to any products or information herein, without notice. The information herein is provided "as-is" and **onsemi** makes no warranty, representation or guarantee regarding the accuracy of the information, product features, availability, functionality, or suitability of its products for any particular purpose, nor does **onsemi** assume any liability arising out of the application or use of any product or circuit, and specifically disclaims any and all liability, including without limitation special, consequential or incidental damages. Buyer is responsible for its products and applications using **onsemi**

---

---