

# CAT3612

## Programmable 300 mA Camera Flash LED Driver

The CAT3612 is a high-efficiency 1x/1.5x fractional charge pump with programmable current in two LED channels. Each channel delivers accurate regulated current up to 150 mA and make CAT3612 ideal for driving one or two flash LEDs.

Low noise operation is achieved by operating at a constant switching frequency of 1 MHz which allows the use of small external ceramic capacitors. The 1x/1.5x fractional charge pump supports a wide range of input voltages from 3 V to 5.5 V with efficiency up to 90%, and is ideal for Li-Ion battery powered devices.

The EN/DIM logic input provides a 1-wire EZDim™ interface for dimming control of the LEDs. When enabled, pulsing the EN/DIM reduces the LED current on each negative edge in 31 linear steps from 150 mA down to zero current.

The device is available in the tiny 12-lead thin DFN 3 mm x 3 mm package with a max height of 0.8 mm.

- Dual Matched Regulated LED Channels
- 300 mA Output Current (150 mA per Channel)
- 1-wire EZDim™ Programmable LED Current
- 32 Accurate Dimming Levels
- Power Efficiency up to 90%
- Fractional Pump 1x/1.5x
- Low Noise Input Ripple
- Fixed High Frequency Operation 1 MHz
- “Zero” Current Shutdown Mode
- Soft Start and Current Limiting
- Short Circuit Protection
- Thermal Shutdown Protection
- 12-lead TDFN 3 mm x 3 mm Package
- These Devices are Pb-Free, Halogen Free/BFR Free and are RoHS Compliant

- Camera Flash
- Cellular Phones
- Digital Still Cameras



-

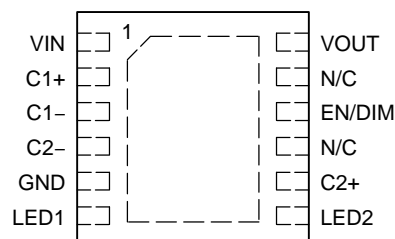

(Top View)



|                            |                      |                       |
|----------------------------|----------------------|-----------------------|
|                            |                      |                       |
| CAT3612HV2-T2<br>(Note 1)  | TDFN-12<br>(Pb-Free) | 2,000/<br>Tape & Reel |
| CAT3612HV2-GT2<br>(Note 2) | TDFN-12<br>(Pb-Free) | 2,000/<br>Tape & Reel |

1. Matte-

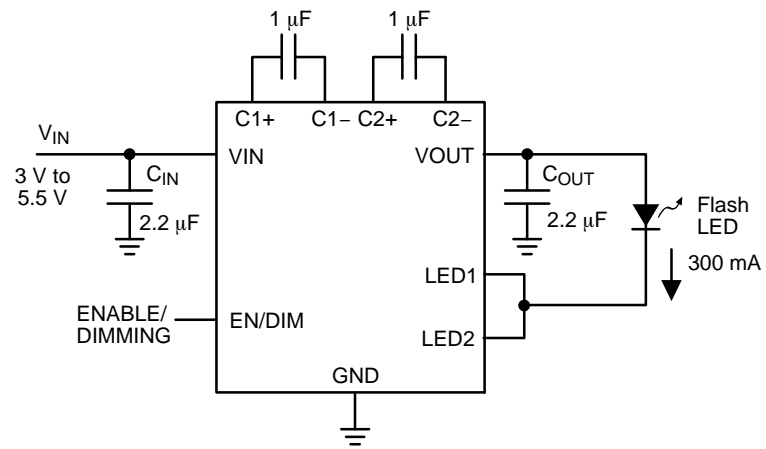

NOTE: Unused LED channel must be connected to VOUT

|                         |   |   |
|-------------------------|---|---|
| VIN, LED1, LED2 voltage | 6 | V |
| VOUT, C1±, C2± voltage  | 7 | V |

(over recommended operating conditions unless specified otherwise) VIN = 3.6 V, EN = High, ambient temperature of 25°C.

|                      |                      |  |   |          |   |    |
|----------------------|----------------------|--|---|----------|---|----|
|                      |                      |  |   |          |   |    |
| I <sub>Q</sub>       | Quiescent Current    | 1x mode, no load<br>1.5x mode, no load |   | 0.5<br>3 |   | mA |
| I <sub>QSHDN</sub>   | Shutdown Current     | V <sub>EN</sub> = 0 V                  |   |          | 1 | μA |
| I <sub>LED-ACC</sub> | LED Current Accuracy | 5 mA ≤ ±4.4 Tm(Tj)/TT2 4 .84           | 5T8 0 0 8 70.44 .few 1 Tf1.3846 .2585 TD0 TcA |          |   |    |



(VIN = 3.6 V, IOUT = 100 mA, CIN = COUT = 2.2 μF, C1 = C2 = 1 μF, TAMB = 25°C unless otherwise specified.)

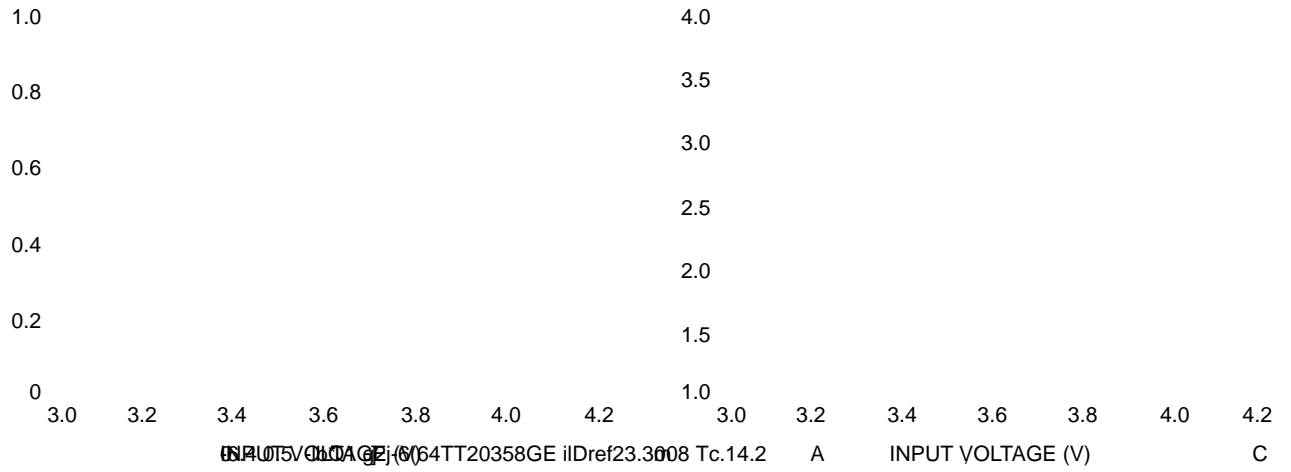
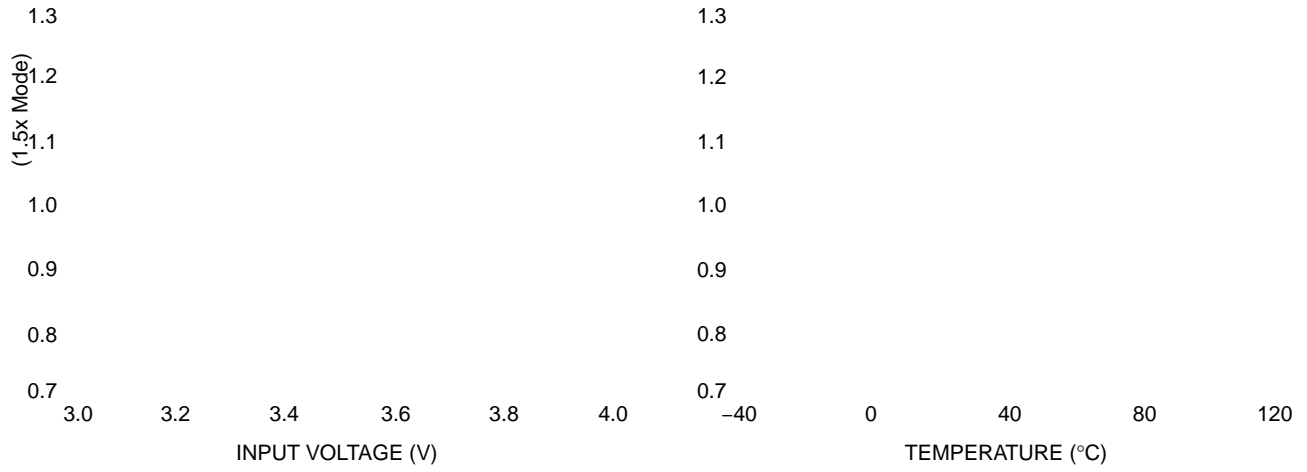
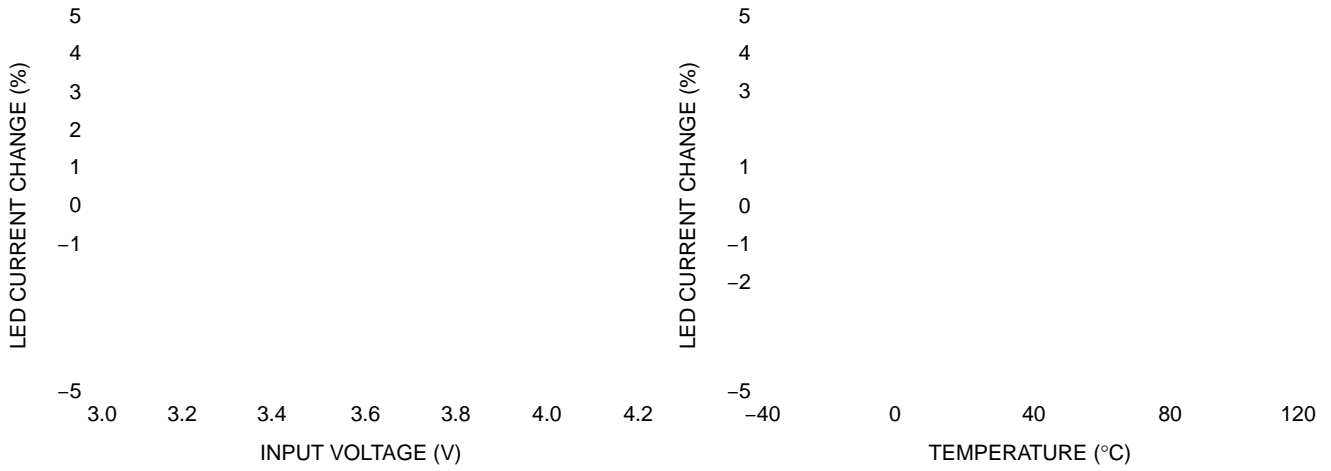

INPUT VOLTAGE (V) 3.0 3.2 3.4 3.6 3.8 4.0 4.2 C 6  
 0 ] m A , 0 mA, CI90.4/TT44.8110Tj2/TT232 m C

(VIN = 3.6 V, IOUT = 100 mA, CIN = COUT = 2.2 μF, C1 = C2 = 1 μF, TAMB = 25°C unless otherwise specified.)

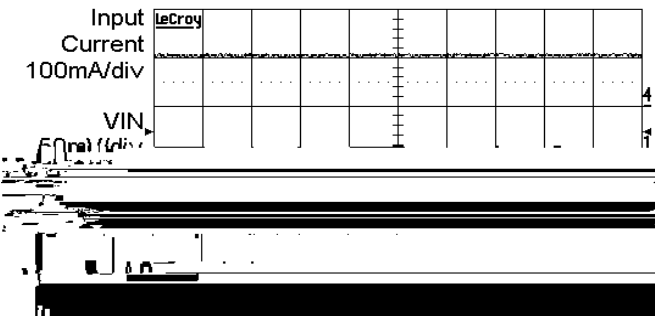
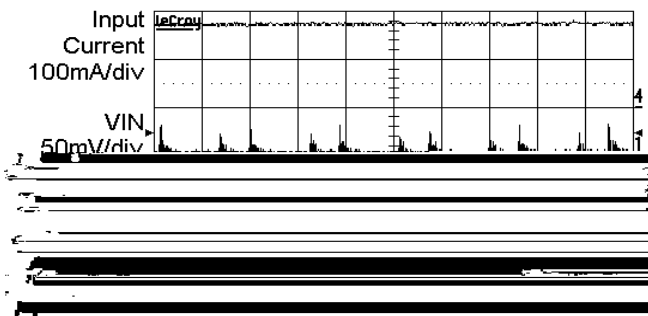
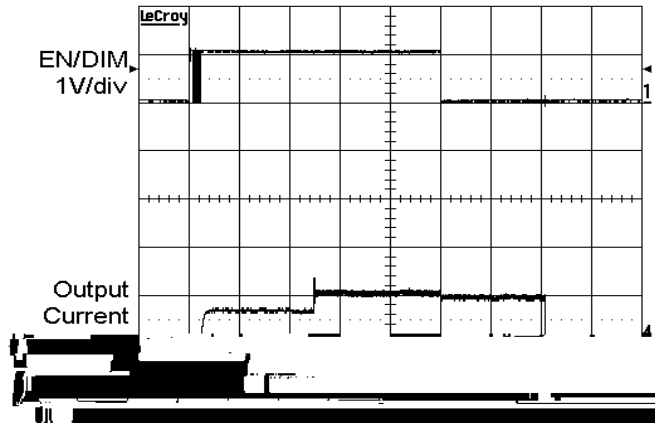
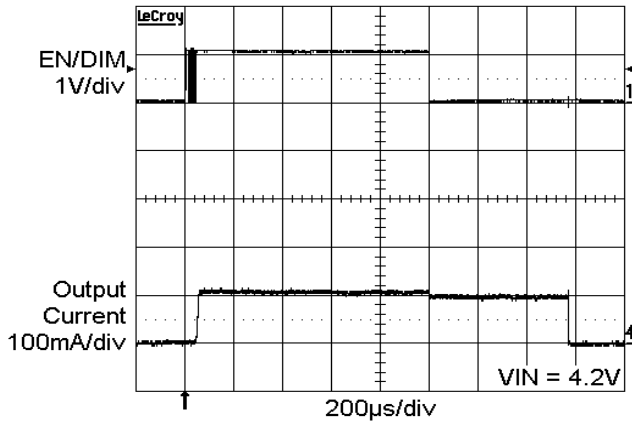
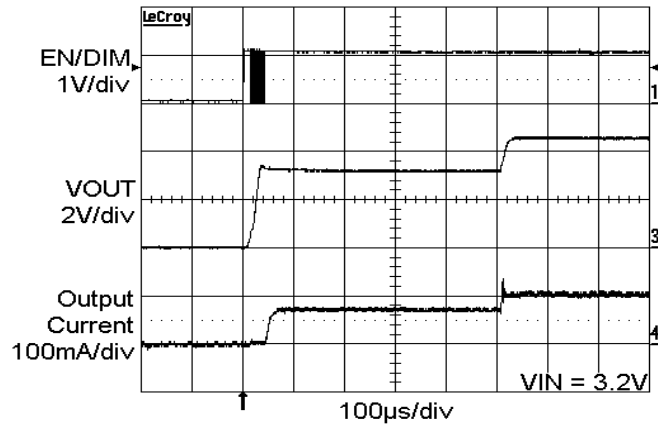
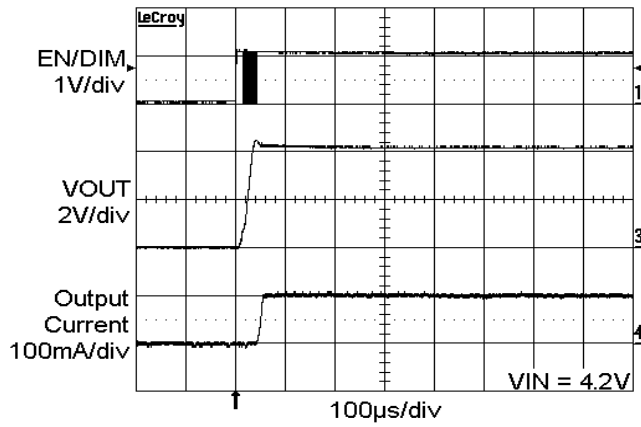



|   |     |                 |
|---|-----|-----------------|
|   |     |                 |
| 1 | VIN | Supply voltage. |
| 2 |     |                 |



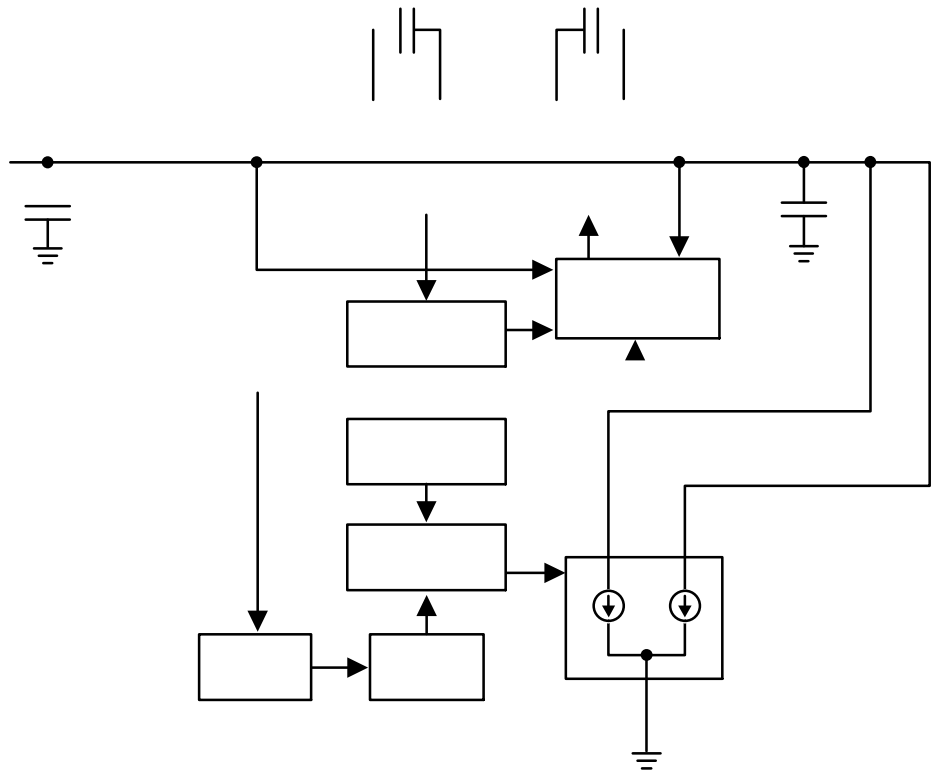



If an LED becomes open-circuit, the output voltage VOUT is internally limited to about 5.5 V. This is to prevent the output pin from exceeding its absolute maximum rating.

The driver enters a thermal shutdown mode as soon as the die temperature exceeds about +165°C. When the device temperature drops down by about 20°C, the device resumes normal operation.

The driver requires a total of four external 1 µF ceramic capacitors: two for decoupling input and output, and two for the charge pump. Both capacitor types X5R and X7R are recommended for the LED driver application. In the 1.5x charge pump mode, the input current ripple is kept very low by design, and an input bypass capacitor of 1 µF is sufficient. In 1x mode, the device operating in linear mode does not introduce switching noise back onto the supply.

In 1.5x charge pump mode, the driver switches internally at a high frequency of 1 MHz. It is recommended to minimize trace length to all four capacitors. A ground plane should cover the area under the driver IC as well as the bypass capacitors. Short connection to ground on capacitors Cin and Cout can be implemented with the use of multiple via. A copper area matching the TDFN exposed pad (GND) must be connected to the ground plane underneath. The use of multiple via improves the package heat dissipation.

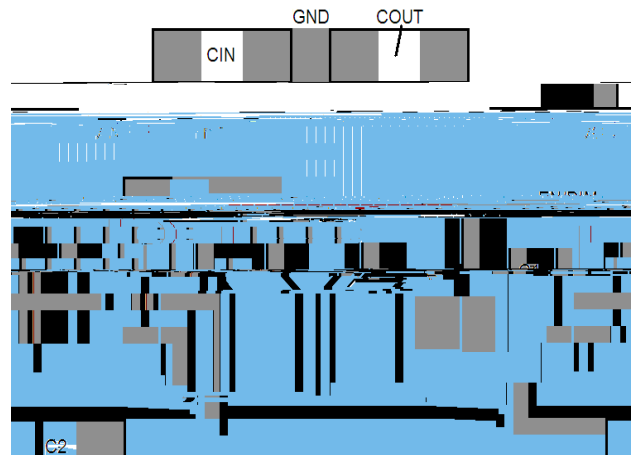

**TDFN12, 3x3**  
CASE 511AN  
ISSUE A

DATE 18 MAR 2009

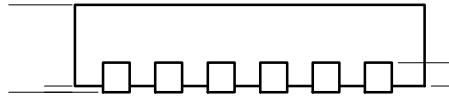
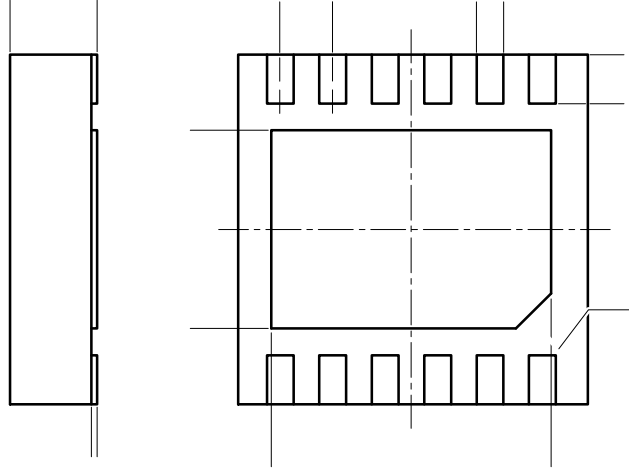

-----

**onsemi**, **onsemi**, and other names, marks, and brands are registered and/or common law trademarks of Semiconductor Components Industries, LLC dba "**onsemi**" or its affiliates and/or subsidiaries in the United States and/or other countries. **onsemi** owns the rights to a number of patents, trademarks, copyrights, trade secrets, and other intellectual property. A listing of **onsemi**'s product/patent coverage may be accessed at [www.onsemi.com/site/pdf/Patent-Marking.pdf](http://www.onsemi.com/site/pdf/Patent-Marking.pdf). **onsemi** reserves the right to make changes at any time to any products or information herein, without notice. The information herein is provided "as-is" and **onsemi** makes no warranty, representation or guarantee regarding the accuracy of the information, product features, availability, functionality, or suitability of its products for any particular purpose, nor does **onsemi** assume any liability arising out of the application or use of any product or circuit, and specifically disclaims any and all liability, including without limitation special, consequential or incidental damages. Buyer is responsible for its products and applications using **onsemi**

---

---