

# STK681-320

<http://onsemi.com>

## Overview

The STK681-320 is a hybrid IC for use in current control forward/reverse DC motor driver with brush.

## Applications

- Office photocopiers, printers, etc.

## Features

- Allows forward, reverse, and brake operations in accordance with the external input signal.
- 5.2A startup output current and 8A peak brake output current.
- Incorporating a current detection resistor (0.056Ω), fixed current control is possible.
- Obviate the need to design for the dead time in order to turn off the upper- and lower drive devices when switching between the forward and reverse operation mode.

## Specifications

**Absolute maximum ratings** at  $T_c = 25^\circ\text{C}$

Parameter	Symbol	Conditions	Ratings	unit
Maximum supply voltage 1	$V_{CC1 \text{ max}}$	$V_{CC2}=0\text{V}$	52	V
Maximum supply voltage 2	$V_{CC2 \text{ max}}$	No signal	-0.3 to +7.0	V
Input voltage	$V_{IN \text{ max}}$	Logic input pins	-0.3 to +7.0	V
Output current	$I_O \text{ max}$	$V_{CC2}=5.0\text{V}$ , DC current	5.2	A
Brake current	$I_{OB \text{ max}}$	$V_{CC2}=5.0\text{V}$ , square wave current, operating time 60ms (single pulse)	8	A
Allowable power dissipation	$P_{dPK \text{ max}}$	No heat sink	3.1	W
Operating storage temperature	$T_{stg}$		-40 to +125	$^\circ\text{C}$

Stresses exceeding Maximum Ratings may damage the device. Maximum Ratings are stress ratings only. Functional operation above the Recommended Operating Conditions is not implied. Extended exposure to stresses above the Recommended Operating Conditions may affect device reliability.

# STK681-320

## Allowable Operating Ranges at $T_a = 25^\circ\text{C}$

Parameter	Symbol	Conditions	Ratings	unit
Operating supply voltage 1	$V_{CC1}$	With signals applied	10 to 42	V
Operating supply voltage 2	$V_{CC2}$	With signals applied	5±5%	V
Input voltage	$V_{IN}$		0 to $V_{CC2}$	V
Output current 1	$I_{O1}$	$V_{CC2}=5.0\text{V}$ , DC current, $T_c \leq 70^\circ\text{C}$	5.2	A
Output current 2	$I_{O2}$	$V_{CC2}=5.0\text{V}$ , DC current, $T_c = 90^\circ\text{C}$	4.2	A
Output current 3	$I_{O3}$	$V_{CC2}=5.0\text{V}$ , DC current, $T_c = 105^\circ\text{C}$	3.5	A
Brake current	$I_{OB}$	$V_{CC2}=5.0\text{V}$ , square wave current, operating time 3.6ms, $T_c = 105^\circ\text{C}$	8	A

Refer to the graph for each conduction-period tolerance range for the output current and brake current.

## Electrical Characteristics at $T_c = 25^\circ\text{C}$ , $V_{CC1} = 24\text{V}$ , $V_{CC2} = 5.0\text{V}$

Parameter	Symbol	Conditions	min	typ	max	unit
$V_{CC2}$ supply current	$I_{CCO}$	Forward or reverse operation		1.7	4	mA
FET diode forward voltage	$V_{df}$	$I_f = 1\text{A}$ ( $R_L = 23\Omega$ )		0.8	1.4	V
Output saturation voltage 1	$V_{sat1}$	$R_L = 23\Omega$ , F1, F2		0.14	0.20	V
Output saturation voltage 2	$V_{sat2}$	$R_L = 23\Omega$ , F3, F4+current detection resistance		0.16	0.23	V
Output leak current	$I_{OL}$	F1, F2, F3, and F4 OFF operation			50	$\mu\text{A}$
Input high voltage 1	$V_{IH1}$	IN1, IN2 pins	4.5			V
Input high voltage 2	$V_{IH2}$	INH pin	2.5			V
Input low voltage	$V_{IL}$	IN1, IN2, INH pins			0.6	V
Input current 1	$I_{IH1}$	IN1, IN2 pins, $V_{IH1} = 5\text{V}$	0.10	0.20	0.40	mA
Input current 2	$I_{IH2}$	INH pin, $V_{IH2} = 5\text{V}$	0.30	0.60	1.2	mA
Current set ting voltage	$V_{ref1}$	Between pins $V_{ref1}$ and S.P		0.29		V

Note: A fixed-voltage power supply must be used.

## Package Dimensions

unit:mm (typ)

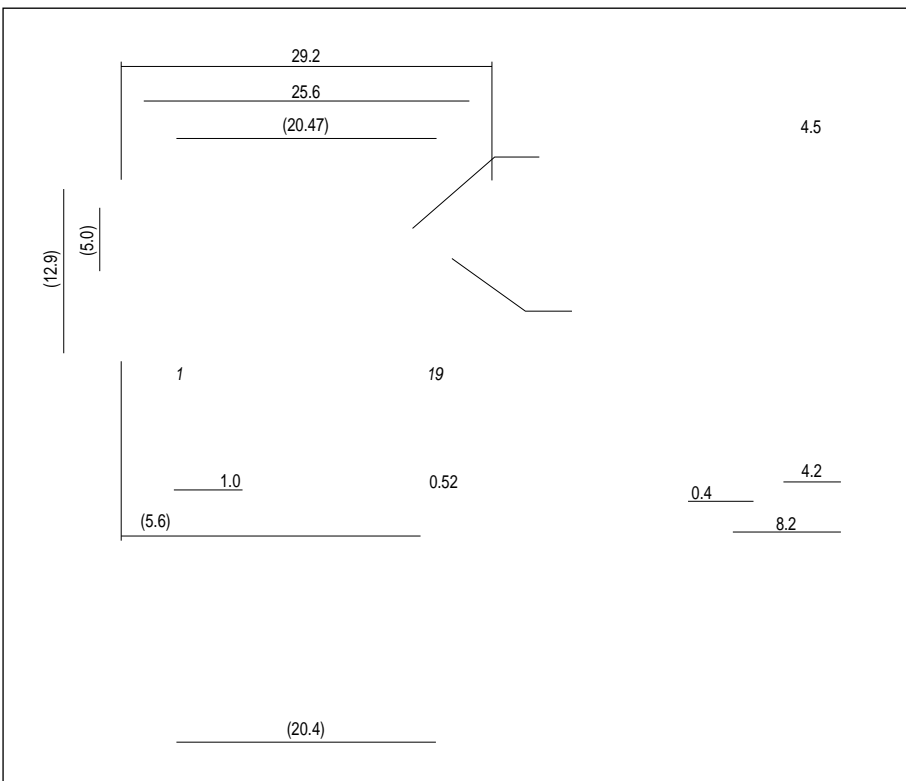

# STK681-320

Derating Curve of Motor Current,  $I_O$ , vs. STK681-320 Operating Board Temperature,  $T_c$

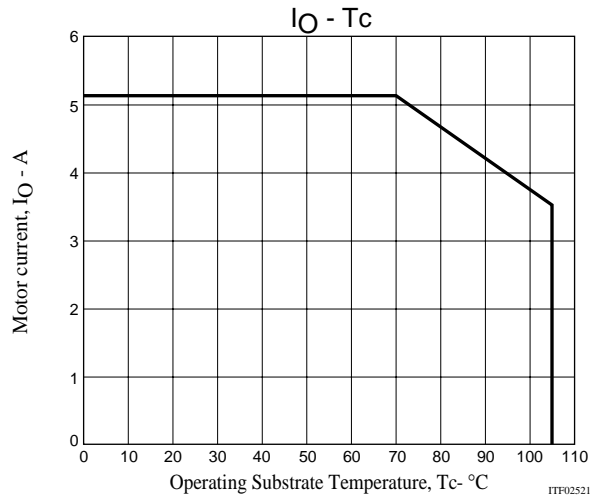

The range of DC operating current lies within the above derating curve in the  $V_{CC1}$  allowable operating range. The above motor current  $I_O$  is valid within the chopping operating range of DC operating. The above operating substrate temperature,  $T_c$ , is measured immediately when the motor is started. Since  $T_c$  fluctuates due to the ambient temperature,  $T_a$ , the motor current value, and continuous or intermittent operations of the motor current, always confirm this values using an actual set.

## STK681-320 Allowable Brake Current Range

9

6

5

2

1

0

Internal Block Diagram

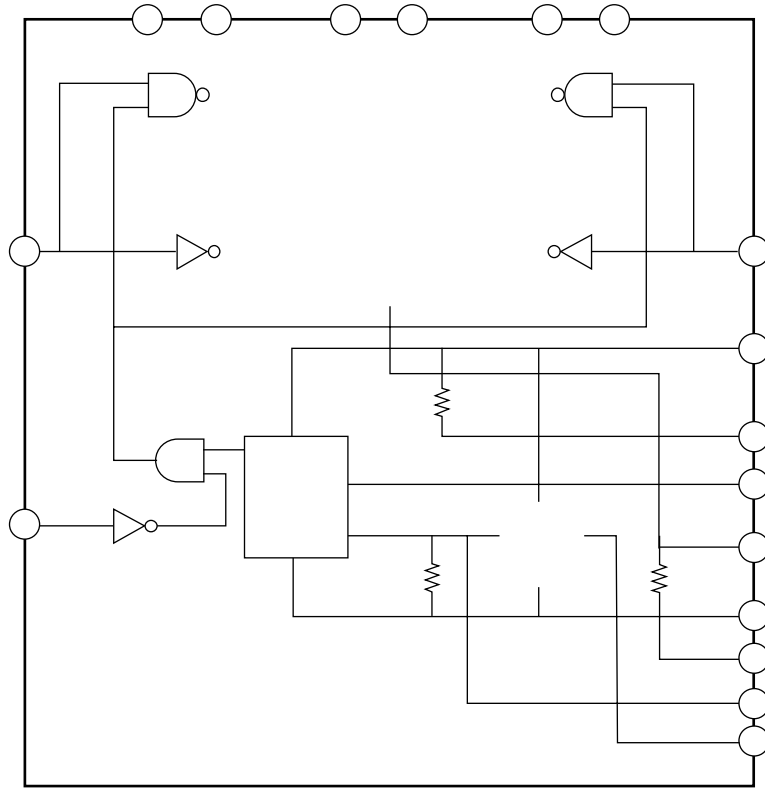

Sample Application Circuit

# STK681-320

## Motor Drive Conditions (H: High-level input; L: Low-Level Input)

	IN1	IN2	INH	Remarks
Stop 1 (standby)	H	H	H or L	When motor is not rotating
Stop 2 (supply power turned off by input during motor rotation)	H	H	H	Stop signal that is applied when the motor is running and used to turn off power.
	H	L	H	
	L	H	H	
Forward (CW)	H	L	L	No input signal is needed that turns off the upper- and lower-side drive devices when switching the rotational direction.
Reverse (CCW)	L	H	L	
Brake	L	L	L or H	GND side MOSFET ON

\* IN1=IN2=H and INH=L are prohibited during motor rotation.

### Notes

- (1) Be sure to set the capacitance of the power supply bypass capacitor, C1, so that the ripple current of the capacitor, which varies as motor current increases, falls within the allowed range.
- (2) Although the Vref2 pin is kept open, if connected to the GND or S.P pin, the overheating current control circuit ceases to function.
- (3) Fixed current chopping operations based on F1 and F2 are used for current control. The timing given below is used for OUT1 or OUT2 voltage output and for F1 or F2 drain current.

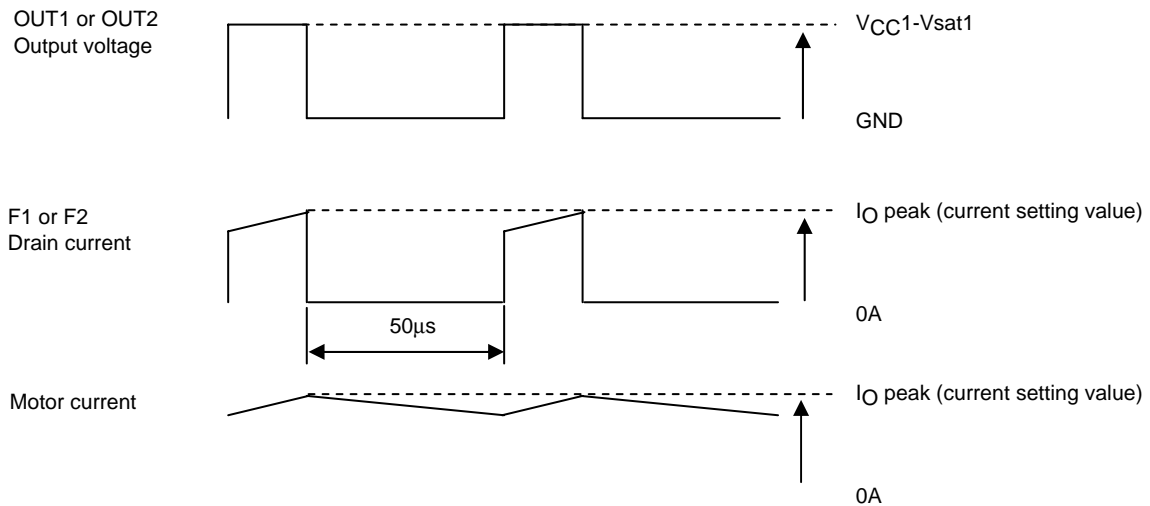

- (4) Do not connect the N.C pins shown in the internal block diagram or sample application circuit to a circuit pattern on the PCB.
- (5) This IC is not designed for use in an H-bridge driver for power supplies because the I/O response time of its GND side driving device, required when switching the motor rotational direction, is several scores of microseconds. It should be used only for DC motor drivers.

(6) Sample Timing Diagram

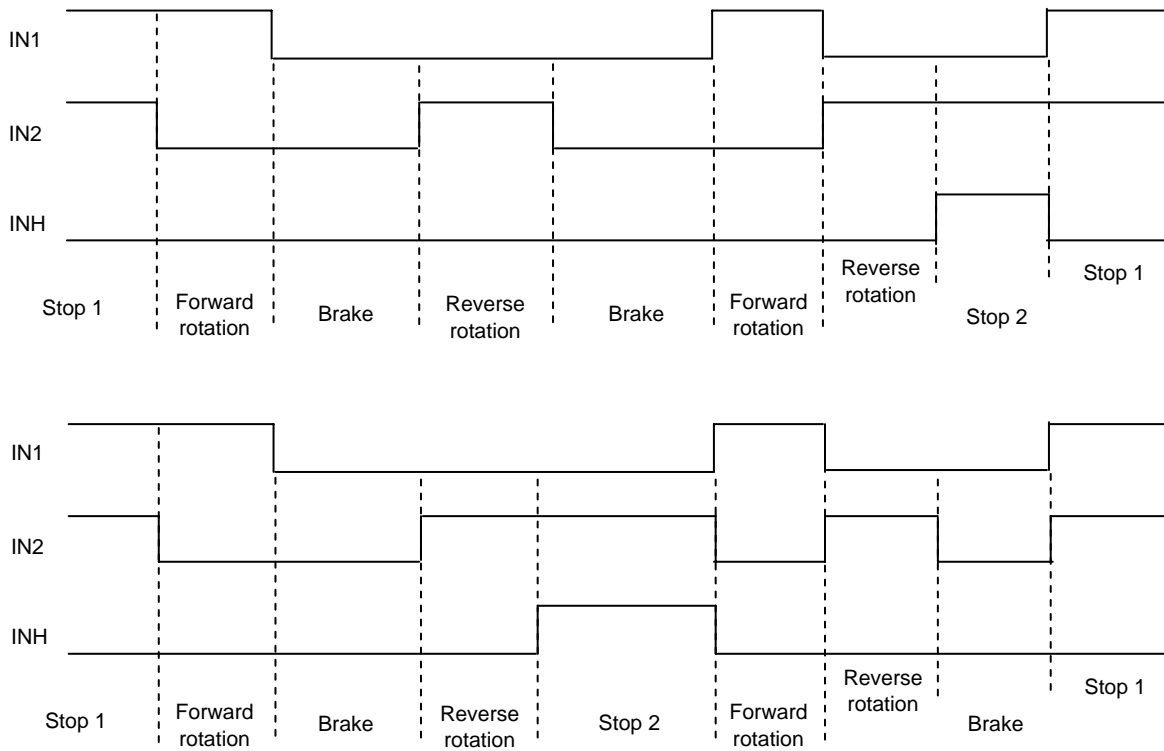

(7) Smoke Emission Precautions: There is a possibility of smoke emission if the hybrid IC is subjected to physical or electrical damage as the result of being used without compliance with the specifications.

**I/O Functions of Each Pin**

Pin Name	Pin No.	Function
IN1	12	Input pin for turning F1 and F3 ON and OFF At high level, F1: ON and F3: OFF; at low level F1: OFF and F3: ON
IN2	13	Input pin for turning F2 and F4 ON and OFF At high level, F2: ON and F4: OFF; at low level, F2: OFF and F4: ON
INH	14	Pin for turning F1 and F2 OFF; At high level F1 and F2: OFF This pin is usually low or open.
OUT1	8	This pin connects to the motor and outputs source/sync current depending on conditions at IN1 and IN2.
OUT2	6	This pin connects to the motor and outputs source/sync current depending on conditions at IN1 and IN2.
Vref1a Vref1b	16 18	This pin is used for current setting for constant-current operation performed with the Vrefa and Vrefb pins connected A voltage of 0.29V at Tc=25°C results for Vref1. 0.29V is set by connecting 82kΩ and 5.1kΩ in series. Current detection resistance is Rs=0.056Ω. Set using $I_{O\ peak} = V_{ref1} / R_s$ .
Vref2	17	Be sure to usually leave this pin open. The overheating control circuit can be made to stop operating by connecting this pin to the GND or S.P pin.
S.P	2	Vref1 voltage can be lowered by connecting a resistor between the Vref1 and S.P pins.
RSO	3	This pin is used to monitor the voltage across the current sensing resistor, Rs. Must be connected to the RSI pin.
RSI	19	This pin is connected to the RSO pin and serves as an input to the circuit that compares the input with Vref1.

Technical Information

(1) Substrate temperature rise,  $\Delta T_c$  (no heat sink) - Internal average power dissipation, PdAV

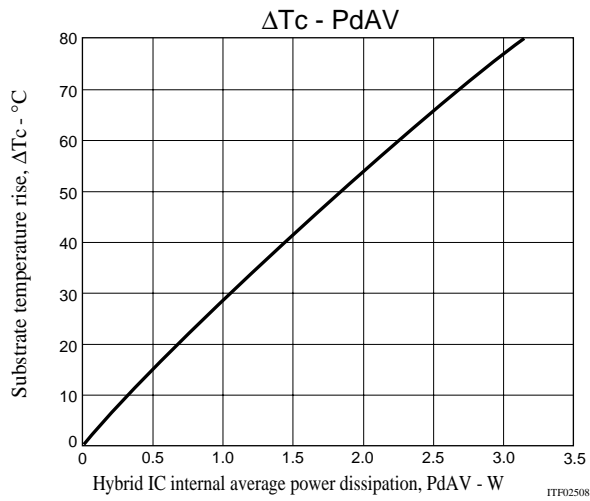

(2) Internal average power dissipation, Pd, in the DC current-motor current, I<sub>Q</sub>, characteristics (typ values for Pd)

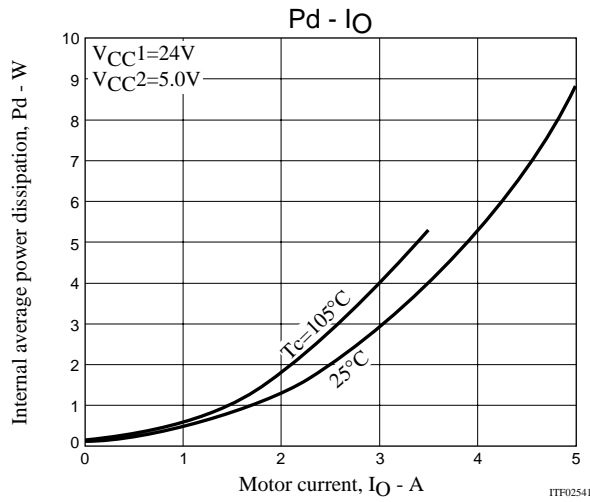

(3) Overheating current control characteristics

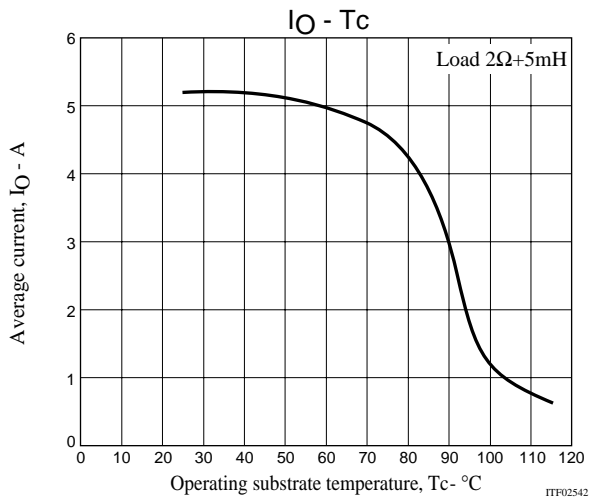

Overheating current control functions to prevent driver failure if a motor lock malfunction occurs.

(4) Derating curve of the package power dissipation, PdPK, against the ambient temperature, Ta



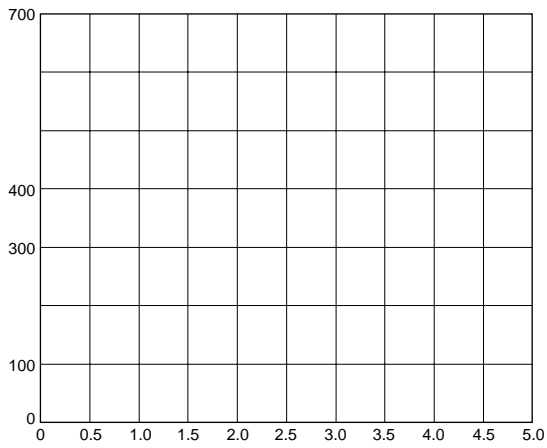

ITF02518

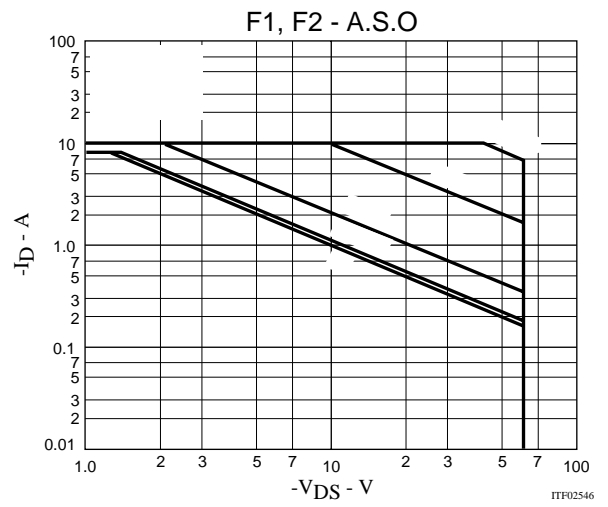

ITF02546

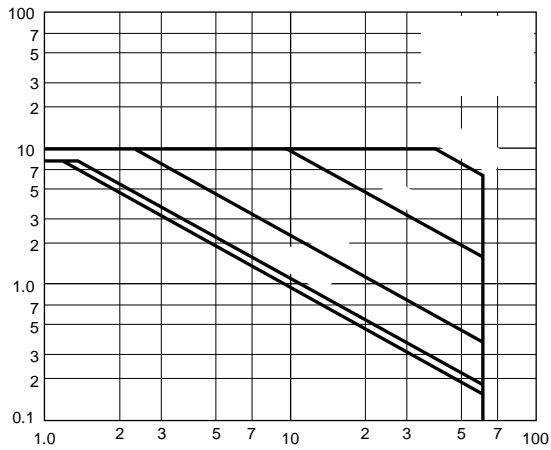

ITF02547

## Input Pin Configurations