

**SIP6 1.45X1.0
CASE 127EB**

**SC-88 (SC-70 6 Lead), 1.25x2
CASE 419AD**

ORDERING INFORMATION

DISCONTINUED. Please refer to the table on page 2.

FSA4157, FSA4157A

ORDERING INFORMATION

Part Number	Top Mark	Package	Shipping†
FSA4157P6X	A57	SC-88 (SC-70 6 Lead), 1.25x2 (Pb-Free)	3000 / Tape & Reel
FSA4157AP6X	B57	SC-88 (SC-70 6 Lead), 1.25x2 (Pb-Free)	3000 / Tape & Reel

DISCONTINUED (Note 1)

FSA4157L6X	EG	SIP6 1.45X1.0 (Pb-Free)	5000 / Tape & Reel
FSA4157AL6X	EU	SIP6 1.45X1.0 (Pb-Free)	5000 / Tape & Reel

†For information on tape and reel specifications, including part orientation and tape sizes, please refer to our Tape and Reel Packaging Specifications Brochure, BRD8011/D.

- DISCONTINUED:** These devices are not recommended for new design. Please contact your **onsemi** representative for information. The most current information on these devices may be available on www.onsemi.com.

PIN CONFIGURATIONS

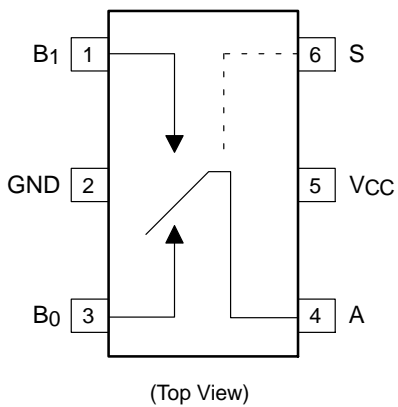

Figure 1. SC70 Pin Assignments

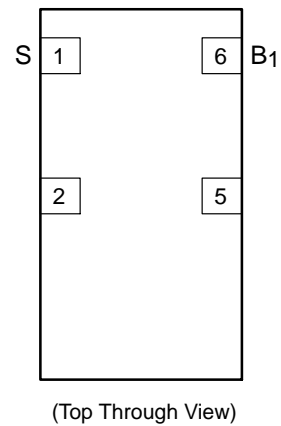

Figure 2. MicroPak Pin Assignments

FSA4157, FSA4157A

ABSOLUTE MAXIMUM RATINGS

Symbol	Parameter	Min	Max	Unit
V _{CC}	Supply Voltage	-0.5	6.0	V
V _S	DC Switch Voltage (Note 2)	-0.5	V _{CC} + 0.5	V
V _{IN}	DC Input Voltage (Note 2)			
I _{IK}	DC Input Diode Current	-50		mA
I _{SW}	Switch Current		200	mA
I _{SWPEAK}	Peak Switch Current (Pulse at 1 ms duration, < 10% Duty Cycle)			
P _D				

FSA4157, FSA4157A

DC ELECTRICAL CHARACTERISTICS

(Typical values are at 25°C unless otherwise specified.)

Symbol	Parameter	Conditions	V _{CC} (V)	Ambient Temperature					Unit
				-25°C			-40 to +85°C		
				Min.	Typ.	Max.	Min.	Max.	
V _{IH}	Input Voltage High	FSA4157 Only	1.8 to 2.7				1.0		V
			2.7 to 3.6				2.0		
			4.5 to 5.5				2.4		
V _{IL}	Input Voltage Low	FSA4157 Only	1.8 to 2.7					0.4	V
		FSA4157A Only	2.7 to 3.6					0.4	
			2.7 to 3.6					0.6	
			4.5 to 5.5					0.8	
I _{IN}	Control Input Leakage	V _{IN} = 0 V to V _{CC}	2.7 to 3.6				-1.0	1.0	μA
			4.5 to 5.5				-1.0	1.0	
I _{NO(OFF)} , I _{NC(OFF)}	Off Leakage Current of Port B0 and B1	A = 1 V, 4.5 V, B ₀ or B ₁ = 4.5, 1 V	5.5		±2		-20	20	nA
I _{A(ON)}	On Leakage Current of Port A	A = 1 V, 4.5V, B ₀ or B ₁ = 4.5, 1 V, 4.5 V or Floating	5.5		±4		-40	40	nA
R _{ON}	Switch On Resistance	I _{OUT} = 100 mA, B ₀ or B ₁ = 1.5 V	2.7		2.6	4.0		4.3	Ω
		I _{OUT} = 100 mA, B ₀ or B ₁ = 3.5 V	4.5		0.95	1.15		1.30	
ΔR _{ON}	On Resistance Matching Between Channels (Note 5)	I _{OUT} = 100 mA, B ₀ or B ₁ = 1.5 V	4.5		0.06	0.12		0.15	Ω
R _{FLAT(ON)}	On Resistance Flatness (Note 5)	I _{OUT} = 100 mA, B ₀ or B ₁ = 0 V, 0.75 V, 1.5 V	2.7		1.4				Ω
		I _{OUT} = 100 mA, B ₀ or B ₁ = 0 V, 1 V, 2 V	4.5		0.2	0.3		0.4	
I _{CC}	Quiescent Supply Current	V _{IN} = 0 V or V _{CC} , I _{OUT} = 0 V	3.6		0.1	0.5		1.0	μA
			5.5		0.1	0.5		1.0	
ΔI _{CC}	Increase in I _{CC} per Input	One Input at 2.7 V, others at V _{CC} or GND (FSA4157A Only)	4.3		0.2			10.0	μA

FSA4157, FSA4157A

TYPICAL PERFORMANCE CHARACTERISTICS

Figure 3. Off Isolation, $V_{CC} = 2.7\text{ V to }5.5\text{ V}$

FSA4157, FSA4157A

TYPICAL PERFORMANCE CHARACTERISTICS (Continued)

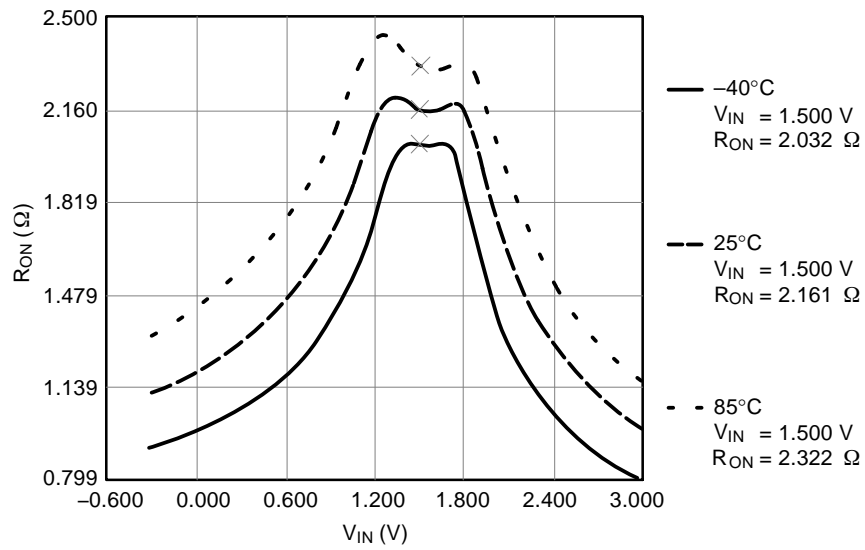

Figure 6. R_{ON} Switch On Resistance, $I_{ON} = 100$ mA, $V_{CC} = 2.7$ V

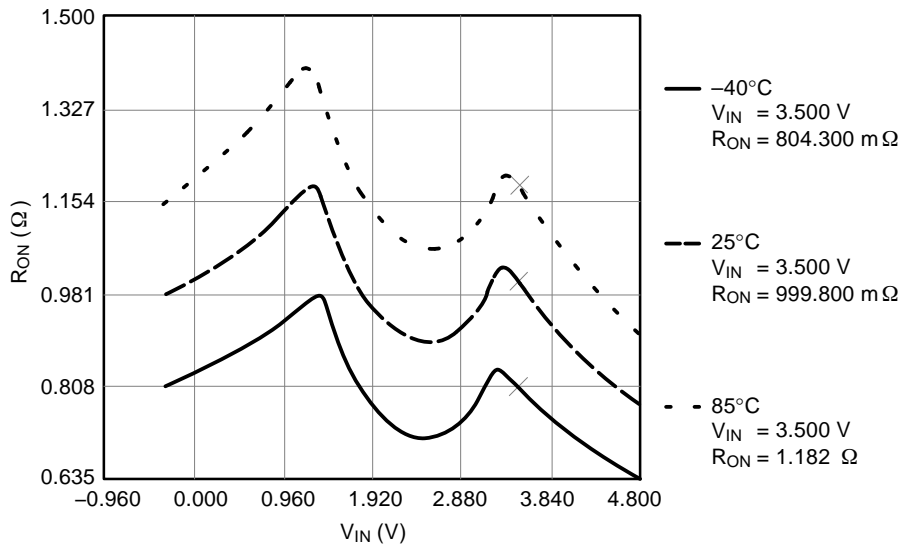

Figure 7. R_{ON} Switch On Resistance, $I_{ON} = 100$ mA, $V_{CC} = 4.5$ V

FSA4157, FSA4157A

AC LOADINGS AND WAVEFORMS

FSA4157, FSA4157A

SIP6 1.45X1.0
CASE 127EB
ISSUE O

DATE 31 AUG 2016

2. DIMENSIONS A 3

CASE 419AD
ISSUE A

DATE 07 JUL 2010

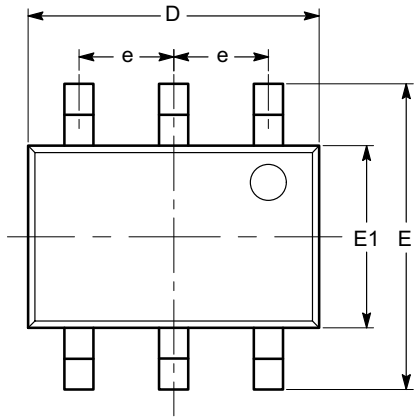

A	0.80		1.10
A1	0.00		0.10
A2	0.80		1.00
b	0.15		0.30
c	0.10		0.18
D	1.80	2.00	2.20
E	1.80	2.10	2.40
E1	1.15	1.25	1.35
e	0.65 BSC		
L	0.26	0.36	0.46
L1	0.42 REF		
L2	0.15 BSC		
θ	0°		8°
θ_1	4°		10°

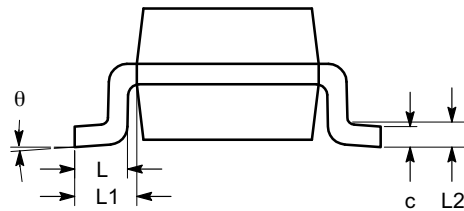
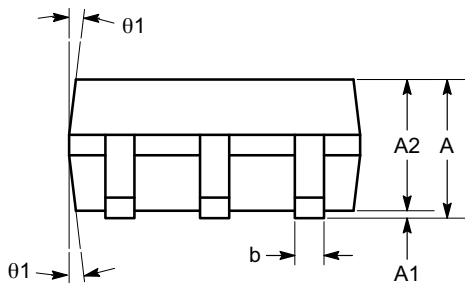

- (1) All dimensions are in millimeters. Angles in degrees.
- (2) Complies with JEDEC MO-203.

onsemi, **onsemi**, and other names, marks, and brands are registered and/or common law trademarks of Semiconductor Components Industries, LLC dba "**onsemi**" or its affiliates and/or subsidiaries in the United States and/or other countries. **onsemi** owns the rights to a number of patents, trademarks, copyrights, trade secrets, and other intellectual property. A listing of **onsemi**'s product/patent coverage may be accessed at www.onsemi.com/site/pdf/Patent-Marking.pdf. **onsemi** reserves the right to make changes at any time to any products or information herein, without notice. The information herein is provided "as-is" and **onsemi** makes no warranty, representation or guarantee regarding the accuracy of the information, product features, availability, functionality, or suitability of its products for any particular purpose, nor does **onsemi** assume any liability arising out of the application or use of any product or circuit, and specifically disclaims any and all liability, including without limitation special, consequential or incidental damages. Buyer is responsible for its products and applications using **onsemi**
