

FUSB3317 is a highly integrated USB Power Delivery (PD) power Source controller for USB-C that implements all functionality of USB Power Delivery 3.1 (PD) and Type-C<sup>™</sup> 2.0 including Programmable Power Supplies (PPS). The FUSB3317 directly interfaces with a DC-DC regulator saving the cost of a load switch FET.

FUSB3317 supports various protections, adaptive Under Voltage Protection (UVP), adaptive Over Voltage Protection (OVP), Over Current Protection (OCP), CC1 and CC2 Over Voltage Protection (CC\_OVP), D+ and D- Over Voltage Protection (D\_OVP), VCONN Over Current Protection (VCONN\_OCP), and internal and external Over Temperature protection (I\_TOP and E\_OTP).

#### Features

-

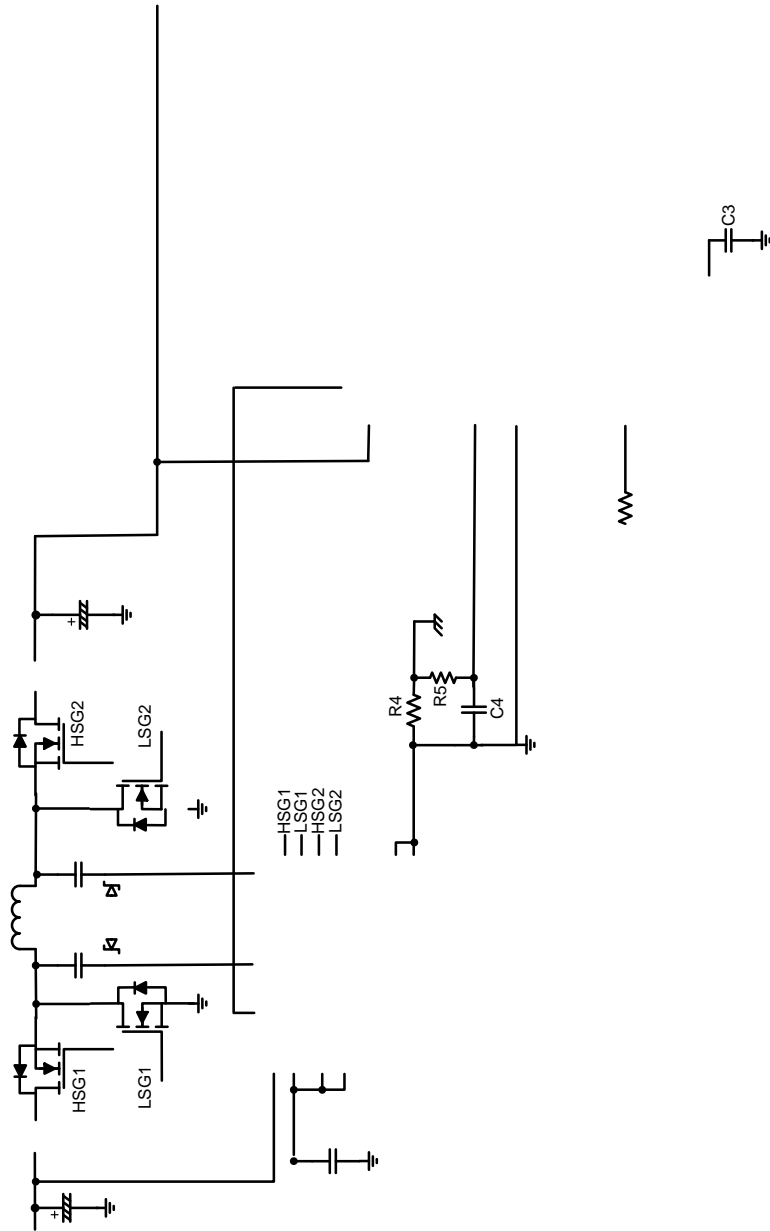
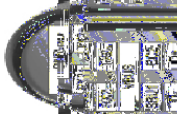

Figure 1. Application Schematic – Automotive DC/DC Reference Design Example

Block Diagram

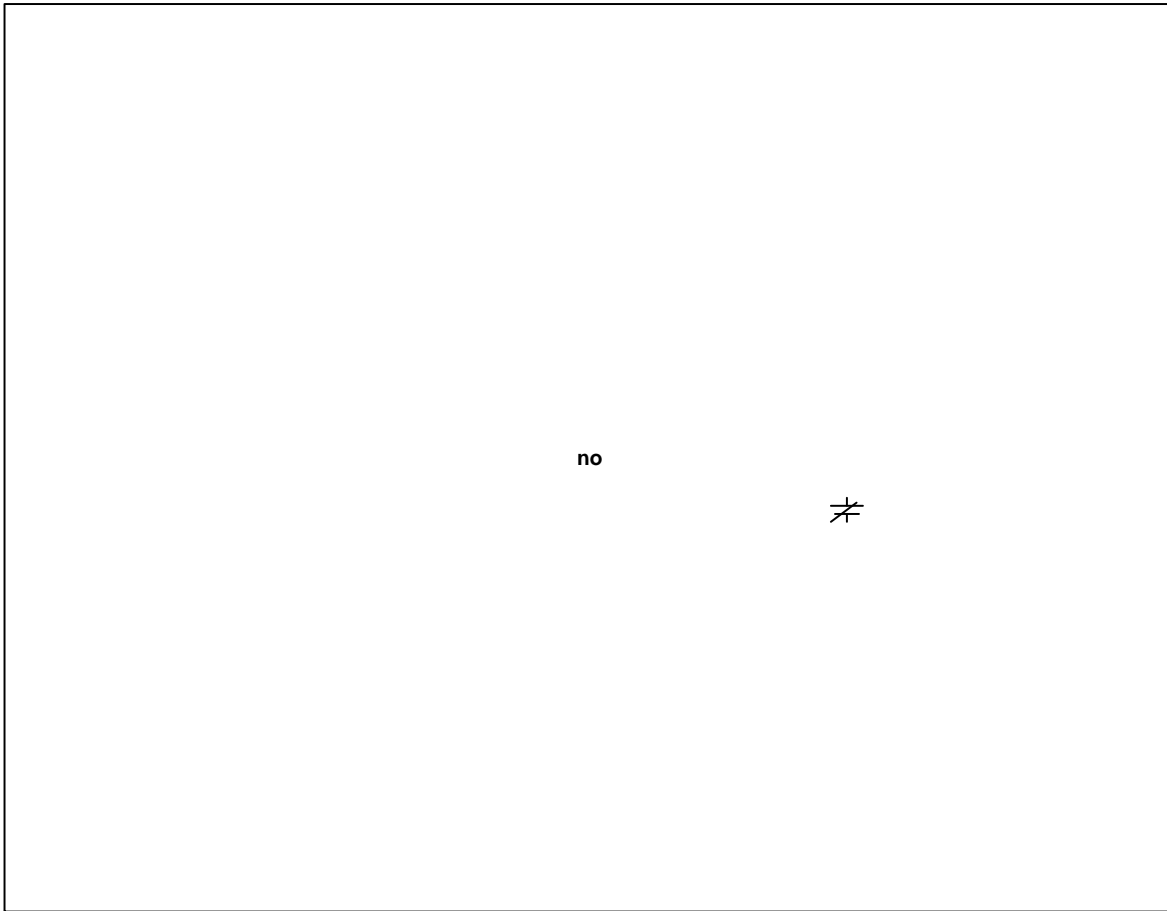

Figure 2. Simplified Block Diagram

# FUSB3317

## PIN FUNCTION DESCRIPTION

Pin No.	Pin Name	I/O Type	Description
11	VBUS	Input	Output VBUS voltage to the Type C connector (Input voltage to the FUSB3317 to check for OVP and UVP)
2	VBAT	Supply	Input power for the FUSB3317 directly from a battery for automotive applications or from a DC-DC supply for industrial
19	VDD	Output	Supply voltage generated internally from VBAT (output from FUSB3317). This pin is connected to a 1 $\mu$ F external capacitor.
13	GND	Ground	Connect to board ground but not connector ground
12	CATH(FB)	Open Drain Output	Feedback to control the power supply. Typically connected to the error amplifier output of a DC-

# FUSB3317

## MAXIMUM RATINGS

Rating	Symbol	Value	Unit
VBAT Battery Pin Voltage (Note 1)	$V_{VBATMAX}$	-0.3 to 54	V
Connector Pins Voltage: VBUS, DISC, CATH, CC1, CC2, D+ and D-	$V_{HIGHMAX}$	-0.3 to 27 V	V
Low Voltage Pins: DC_EN, DON, IS-, VFB, IFG, BATUV, NTC, PDIV1 and PDIV0	$V_{LOWMAX}$	-0.3 to 6 V	V
Supply Output Range on Pin VDD	$V_{VDDMAX}$	-0.3 to 6 V	V
Current Sense Input on Pin IS+	$V_{IS+MAX}$	IS- + 0.1	V
Maximum Junction Temperature	$T_{J(max)}$	150	°C
Storage Temperature Range	$T_{STG}$	-65 to 150	°C
ESD Capability, Human Body Model (Note 2)	$ESD_{HBM}$	2	kV
ESD Capability, Charged Device Model (Note 2)	$ESD_{CDM}$	750	V
Lead Temperature Soldering Reflow (SMD Styles Only), Pb-Free Versions (Note 3)	$T_{SLD}$	260	°C

Stresses exceeding those listed in the Maximum Ratings table may damage the device. If any of these limits are exceeded, device functionality should not be assumed, damage may occur and reliability may be affected.

1. Refer to ELECTRICAL CHARACTERISTICS, RECOMMENDED OPERATING RANGES and/or APPLICATION INFORMATION for Safe Operating parameters.
2. This device series incorporates ESD protection and is tested by the following methods:  
 ESD Human Body Model tested per AEC-Q100-002 (EIA/JESD22-A114)  
 ESD Charged Device Model tested per AEC-Q100-011 (EIA/JESD22-



# FUSB3317

## ELECTRICAL CHARACTERISTICS (continued)

For typical values,  $V_{VBAT} = 12\text{ V}$  and  $T_A = 25^\circ\text{C}$ . For min/max values,  $V_{VBAT} = 5.5\text{ V}$  to  $36\text{ V}$  and  $T_J = -40^\circ\text{C}$  to  $125^\circ\text{C}$ ; unless otherwise noted.

Parameter	Test Conditions	Symbol	Min	Typ	Max	Unit
<b>Over Current Protection (OCP) Sensing Section</b>						
Over Current Protection (OCP) threshold percentage of maximum current	PD request for constant voltage mode with VBUS at 5.2 V and 3 A maximum current	IOCP-PER	109	120	124	%
OCP debounce time	Constant current exceeding IOCP-PER	tOCP-DEB	50	60	70	ms
Current threshold on sensing resistor for enabling discharge on DISC pin during a voltage transition	VBUS is decreasing	ICS-DSCG		430		mA
Debounce time for enabling discharge on DISC pin during a voltage transition	VBUS is decreasing	tCS-DSCG		0.6	1.0	ms
<b>Constant Voltage Sensing Section</b>						
VFB Reference Voltage at 3.3 V	VBUS = 3.3 V, current sense resistor voltage, $V_{cs} = 0\text{ V}$	$V_{CVR-3.3V}$	0.32	0.33	0.34	V
VFB Reference Voltage at 5.2 V nominal output voltage	VBUS = 5.2 V, current sense resistor voltage, $V_{cs} = 0\text{ V}$	$V_{CVR-5V}$	0.504	0.520	0.536	V
VFB Reference Voltage at 9 V nominal output voltage	VBUS = 9 V, current sense resistor voltage, $V_{cs} = 0\text{ V}$	$V_{CVR-9V}$	0.873	0.900	0.927	V
VFB Reference Voltage at 15 V nominal output voltage	VBUS = 15 V, current sense resistor voltage, $V_{cs} = 0\text{ V}$	$V_{CVR-15V}$	1.455	1.500	1.545	V
VFB Reference Voltage at 20 V nominal output voltage	VBUS = 20 V, current sense resistor voltage, $V_{cs} = 0\text{ V}$	$V_{CVR-20V}$	1.940	2.000	2.060	V
<b>Feedback Section</b>						
CATH(FB) pin sink/source current (Note 5)	CATH(FB) as a sink (Note 6)	$I_{CATH-SNK}$	2			mA
CATH(FB) pin sink/source current (Note 5)	CATH(FB) as a source (Note 6)	$I_{FB-SRC}$			-2	mA
<b>Discharge Section</b>						
VBUS to GND Leakage Resistance	DC_EN = 0 V, VBUS not sourced	$R_{DISC-VBUS}$	72.4	155		k $\Omega$
VBUS Pin Sink Current	VBUS = 20 V and being discharged	$I_{DISC-SNK}$	250			mA
Discharge Time	During VBUS voltage transition of voltage step $\leq 0.5\text{ V}$ , final $V_{VBUS} > 13\text{ V}$	$t_{DISC-11}$	5.5	7	8.5	ms
Discharge Time	During VBUS voltage transition of voltage step $\leq 0.5\text{ V}$ , final $V_{VBUS} < 13\text{ V}$	$t_{DISC-10}$	51	55	60	ms
Discharge Time	During VBUS voltage transition of voltage step $> 0.5\text{ V}$ , final $V_{VBUS} > 13\text{ V}$					

**FUSB3317**



# FUSB3317

## APPLICATIONS INFORMATION

FUSB3317 has the entire Power Delivery (PD) communication stack within hardware including the





Figure 8. Voltage and Current Sensing Circuits



Figure 9. Protection Block Diagram

## FUSB3317

### **PDIV0, PDIV1**

These pins are prepared in addition to the fuse bits to provide a

# FUSB3317

## REFERENCES AND DEFINITIONS



QFNW20 4x4, 0.5P

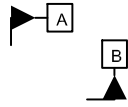

0 FROM THE

TOP VIEW

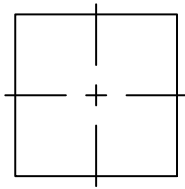

GENERIC  
MARKING DIAGRAM\*

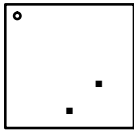

▪

▪

**onsemi**, **onsemi**, and other names, marks, and brands are registered and/or common law trademarks of Semiconductor Components Industries, LLC dba "**onsemi**" or its affiliates and/or subsidiaries in the United States and/or other countries. **onsemi** owns the rights to a number of patents, trademarks, copyrights, trade secrets, and other intellectual property. A listing of **onsemi**'s product/patent coverage may be accessed at [www.onsemi.com/site/pdf/Patent-Marking.pdf](http://www.onsemi.com/site/pdf/Patent-Marking.pdf). **onsemi** reserves the right to make changes at any time to any products or information herein, without notice. The information herein is provided "as-is" and **onsemi** makes no warranty, representation or guarantee regarding the accuracy of the information, product features, availability, functionality, or suitability of its products for any particular purpose, nor does **onsemi** assume any liability arising out of the application or use of any product or circuit, and specifically disclaims any and all liability, including without limitation special, consequential or incidental damages. Buyer is responsible for its products and applications using **onsemi**

---

---