

-3.3 / -
100 **0**

Description

The MC100LVEL90 is a triple ECL to LVPECL translator. The device receives either

MC100LEVEL90

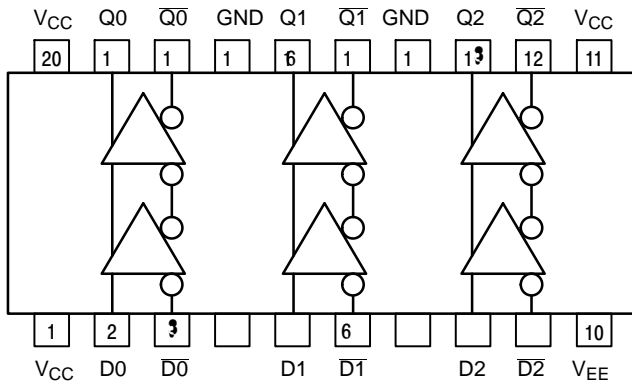

Table 1. PIN DESCRIPTION

PIN	FUNCTION
D _n , D̄ _n	ECL Inputs
Q _n , Q̄ _n	LVPECL Outputs
ECL V _{BB}	ECL Reference Voltage Output
V _{CC}	Positive Supply
V _{EE}	Negative Supply
GND	Ground

* All V_{CC} pins are tied together on the die.

Warning: All V_{CC}, V_{EE}, and GND pins must be externally connected to Power Supply to guarantee proper operation.

Figure 1. Logic Diagram and Pinout: 20-Lead SOIC (Top View)

Table 2. MAXIMUM RATINGS

Symbol

MC100LVEL90

Table 3. NECL INPUT DC CHARACTERISTICS ($V_{CC}= 3.3\text{ V}$; $V_{EE}= -3.3\text{ V}$; $GND= 0\text{ V}$ (Note 1))

Symbol	Characteristic	-40 C			25 C			85 C			Unit
		Min	Typ	Max	Min	Typ	Max	Min	Typ	Max	
I_{EE}	V_{EE} Power Supply Current			8.0		6.0	8.0			8.0	mA
V_{IH}	Input HIGH Voltage (Single-Ended)	-1165		-880	-1165						

Table 5. AC CHARACTERISTICS

MC100LVEL90

Resource Reference of Application Notes

[AN1405/D](#)

SOIC-20 WB
CASE 751D-05
ISSUE H

DATE 22 APR 2015

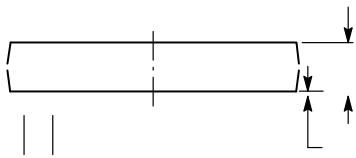

onsemi, **onsemi**, and other names, marks, and brands are registered and/or common law trademarks of Semiconductor Components Industries, LLC dba "**onsemi**" or its affiliates and/or subsidiaries in the United States and/or other countries. **onsemi** owns the rights to a number of patents, trademarks, copyrights, trade secrets, and other intellectual property. A listing of **onsemi**'s product/patent coverage may be accessed at www.onsemi.com/site/pdf/Patent-Marking.pdf. **onsemi** reserves the right to make changes at any time to any products or information herein, without notice. The information herein is provided "as-is" and **onsemi** makes no warranty, representation or guarantee regarding the accuracy of the information, product features, availability, functionality, or suitability of its products for any particular purpose, nor does **onsemi** assume any liability arising out of the application or use of any product or circuit, and specifically disclaims any and all liability, including without limitation special, consequential or incidental damages. Buyer is responsible for its products and applications using **onsemi**
