

MC33341

Power Supply Battery Charger Regulation Control Circuit

The MC33341 is a monolithic regulation control circuit that is specifically designed to close the voltage and current feedback loops in power supply and battery charger applications. This device features the unique ability to perform source high-side, load high-side, source low-side and load low-side current sensing, each with either an internally fixed or externally adjustable threshold. The various current sensing modes are accomplished by a means of selectively using the internal differential amplifier, inverting amplifier, or a direct input path. Positive voltage sensing is performed by an internal voltage amplifier. The voltage amplifier threshold is internally fixed and can be externally adjusted in all low-side current sensing applications. An active high drive output is provided to directly interface with economical optoisolators for isolated output power systems. This device is available in 8-lead dual-in-line and surface mount packages.

Features

- Differential Amplifier for High-Side Source and Load Current Sensing
- Inverting Amplifier for Source Return Low-Side Current Sensing
- Non-Inverting Input Path for Load Low-Side Current Sensing
- Fixed or Adjustable Current Threshold in All Current Sensing Modes
- Positive Voltage Sensing in All Current Sensing Modes
- Fixed Voltage Threshold in All Current Sensing Modes
- Adjustable Voltage Threshold in All Low-Side Current Sensing Modes
- Output Driver Directly Interfaces with Economical Optoisolators
- Operating Voltage Range of 2.3 V to 16 V
- Pb-Free Packages are Available

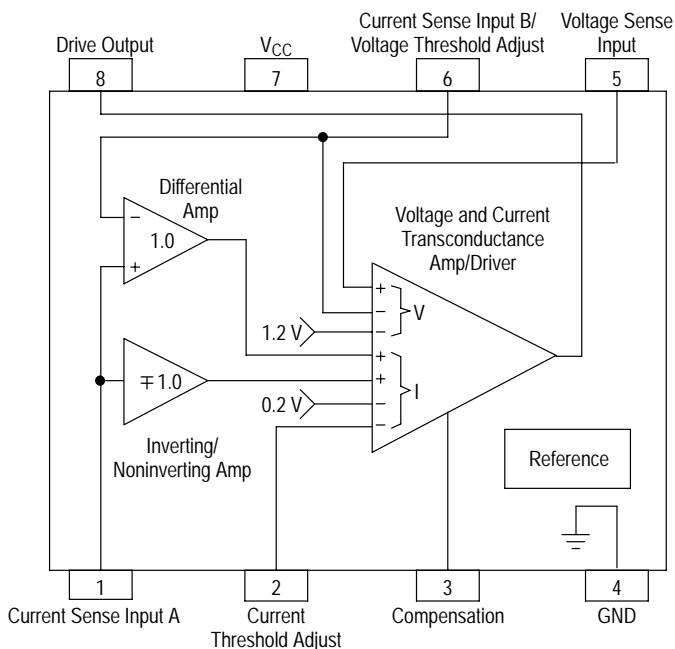

This device contains 114 active transistors.

Figure 1. Representative Block Diagram



<http://onsemi.com>

MARKING DIAGRAMS

**SOIC-8
D SUFFIX
CASE 751**

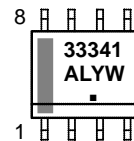

**PDIP-8
P SUFFIX
CASE 626**

1

A = Assembly Location
L, WL = Wafer Lot
Y, YY = Year
W, WW = Work Week
▪ or G = Pb-Free Package
(Note: Microdot may be in either location)

PIN CONNECTIONS

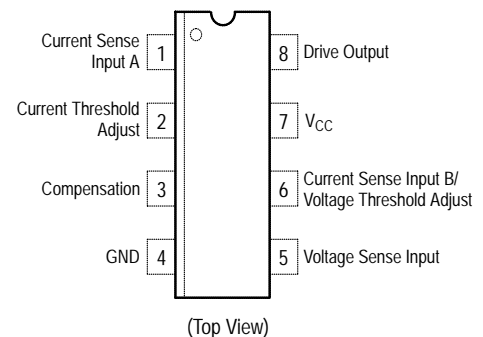

ORDERING INFORMATION

See detailed ordering and shipping information in the package dimensions section on page 17 of this data sheet.

MC33341

MAXIMUM RATINGS

Rating	Symbol	Value	Unit
Power Supply Voltage (Pin 7)	V_{CC}	16	V
Voltage Range Current Sense Input A (Pin 1) Current Threshold Adjust (Pin 2) Compensation (Pin 3) Voltage Sense Input (Pin 5) Current Sense Input B / Voltage Threshold Adjust (Pin 6) Drive Output (Pin 8)	V_{IR}	-1.0 to V_{CC}	V
Drive Output Source Current (Pin 8)	I_{Source}	50	mA
Thermal Resistance, Junction-to-Air P Suffix, DIP Plastic Package, Case 626 D Suffix, SO-8 Plastic Package, Case 751	$R_{\theta JA}$	100 178	°C/W
Operating Junction Temperature (Note 1)	T_J	-25 to +150	°C
Storage Temperature	T_{stg}	-55 to +150	°C

NOTE: ESD data available upon request.

Stresses exceeding Maximum Ratings may damage the device. Maximum Ratings are stress ratings only. Functional operation above the Recommended Operating

MC33341

ELECTRICAL CHARACTERISTICS ($V_{CC} = 6.0\text{ V}$, $T_A = 25^\circ\text{C}$, for min/max values T_A is the operating junction temperature range that applies (Note 1), unless otherwise noted.)

Characteristic	Symbol	Min	Typ	Max	Unit
DIFFERENTIAL AMPLIFIER DISABLE LOGIC (Pins 1, 6)					
Logic Threshold Voltage Pin 1 (Pin 6 = 0 V) Enabled, High-Side Source and Load Current Sensing	$V_{th(I\ HS)}$	–	≥ 1.7	–	V
Disabled, Low-Side Load and Source Return Current Sensing	$V_{th(I\ LS)}$	–	≤ 1.3	–	
VOLTAGE SENSING (Pins 5, 6)					
Positive Sensing Pin 5 to Pin 4 Internally Fixed Threshold Voltage $T_A = 25^\circ\text{C}$	$V_{th(V)}$	1.186	1.210	1.234	V
$T_A = T_{low}$ to T_{high}		1.174	–	1.246	V
Externally Adjusted Threshold Voltage (Pin 6 = 0 V)		–	40	–	mV
Externally Adjusted Threshold Voltage (Pin 6 = 1.2 V)		–	1.175	–	V
Voltage Sense, Input Bias Current (Pin 5)	$I_{B(V)}$	–	10	–	nA
Transconductance, Voltage Sensing Inputs to Drive Output	$g_{m(V)}$	–	7.0	–	mhos
DRIVE OUTPUT (Pin 8)					
High State Source Voltage ($I_{Source} = 10\text{ mA}$)	V_{OH}	–	$V_{CC} - 0.8$	–	V
High State Source Current (Pin 8 = 0 V)	I_{Source}	15	20	–	mA
TOTAL DEVICE (Pin 7)					
Operating Voltage Range	V_{CC}	2.5 to 15	2.3 to 15	–	V
Power Supply Current ($V_{CC} = 6.0\text{ V}$)	I_{CC}	–	300		

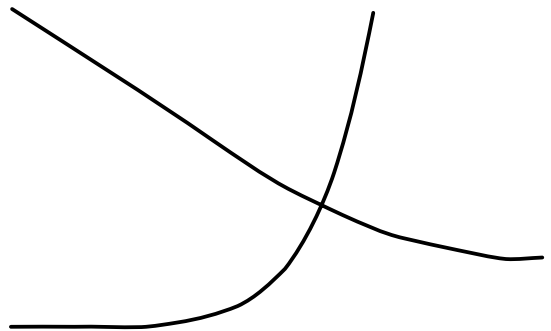
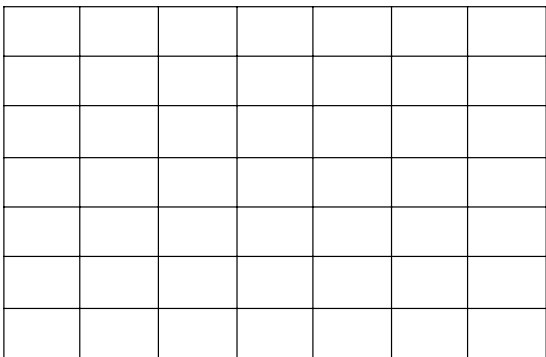

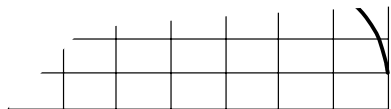
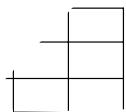

INTRODUCTION

Power supplies and battery chargers require precise control of output voltage and current in order to prevent catastrophic damage to the system load. Many present day power sources contain a wide assortment of building blocks and glue devices to perform the required sensing for proper regulation. Typical feedback loop circuits may consist of a voltage and current amplifier, level shifting circuitry, summing circuitry and a reference. The MC33341 contains all of these basic functions in a manner that is easily adaptable to many of the various power source-load configurations.

OPERATING DESCRIPTION

The MC33341 is an analog regulation control circuit that is specifically designed to simultaneously close the voltage and current feedback loops in power supply and battery charger applications. This device can control the feedback loop in either constant-voltage or constant-current mode with automatic crossover. A concise description of the integrated circuit blocks is given below. Refer to the block diagram in Figure 14.

Transconductance Amplifier

A quad input transconductance amplifier is used to control the feedback loop. This amplifier has separate voltage and current channels, each with a sense and a threshold input. Within a given channel, if the sense input level exceeds that of the threshold input, the amplifier output is driven high. The channel with the largest difference between the sense and threshold inputs will set the output source current of the amplifier and thus dominate control of the feedback loop.

MC33341

Pin 8 to ground. This configuration is shown for ease of understanding and would normally be used to provide an isolated control signal to a primary side switching regulator controller. In non-isolated, primary or secondary side applications, a load resistor can be placed from Pin 8 to ground. This resistor will convert the Drive Output current to a voltage for direct control of a regulator.

In applications where excessively high peak currents are possible from the source or load, the load induced voltage

drop across R_S could exceed 1.6 V. Depending upon the current sensing configuration used, this will result in forward biasing of either the internal V_{CC} clamp diode, Pin 6, or the device substrate, Pin 1. Under these conditions, input series resistor R3 is required. The peak input current should be limited to 20 mA. Excessively large values for R3 will degrade the current sensing accuracy. Figure 22 shows a method of bounding the voltage drop across R_S without sacrificing current sensing accuracy.

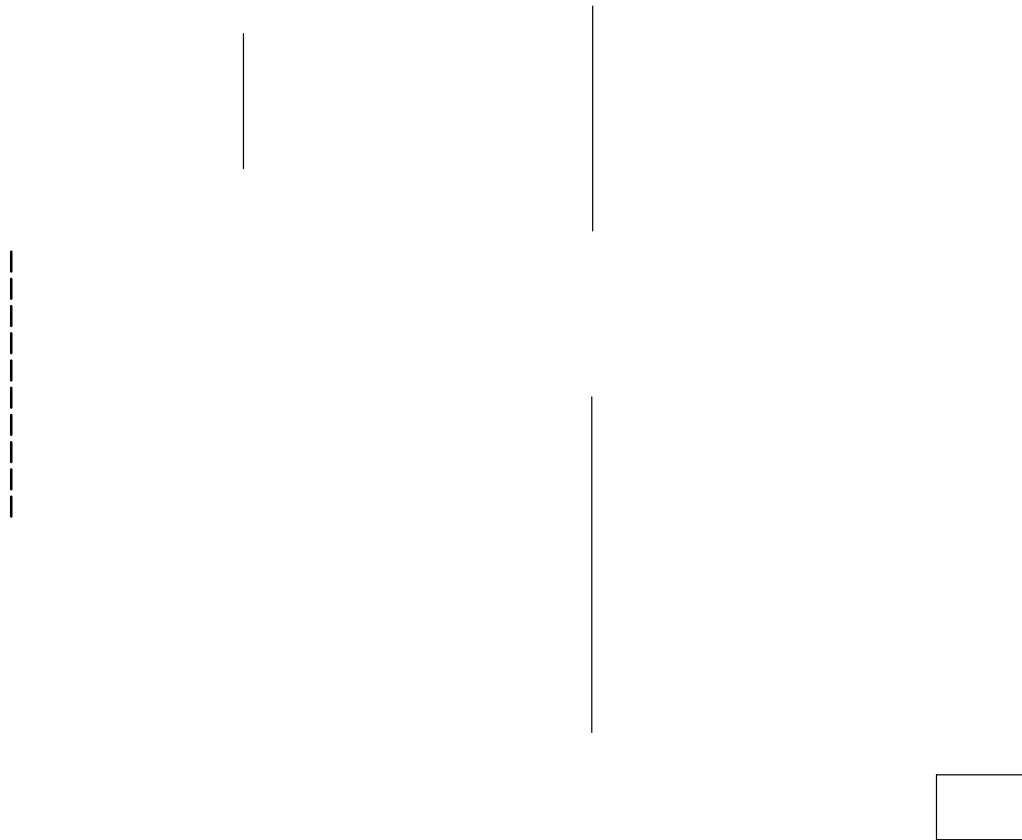

MC33341

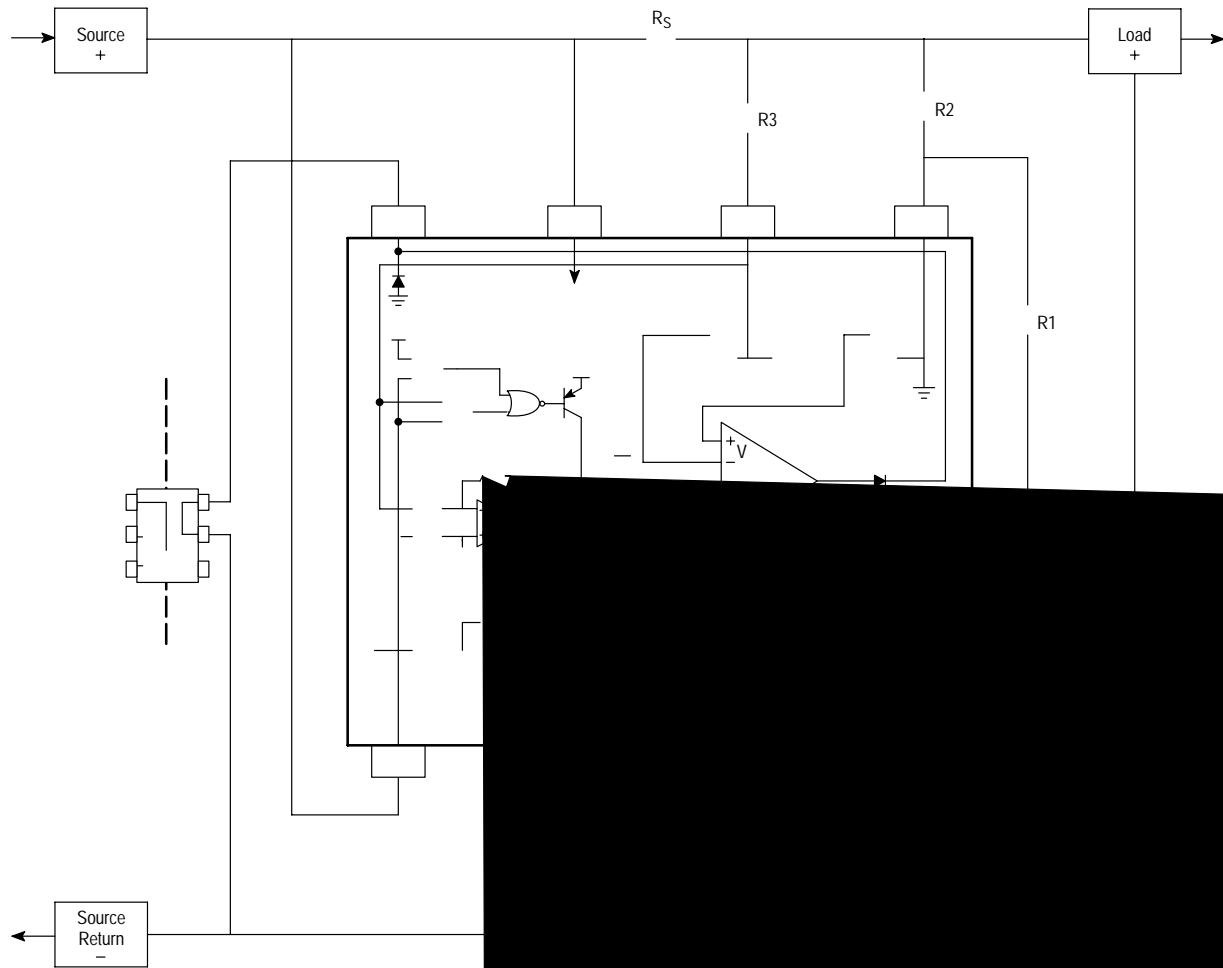

The above figure shows the MC33341 configured as a motor driver. Operation of this circuit is similar to that of Figure 1 except to Pin 4.

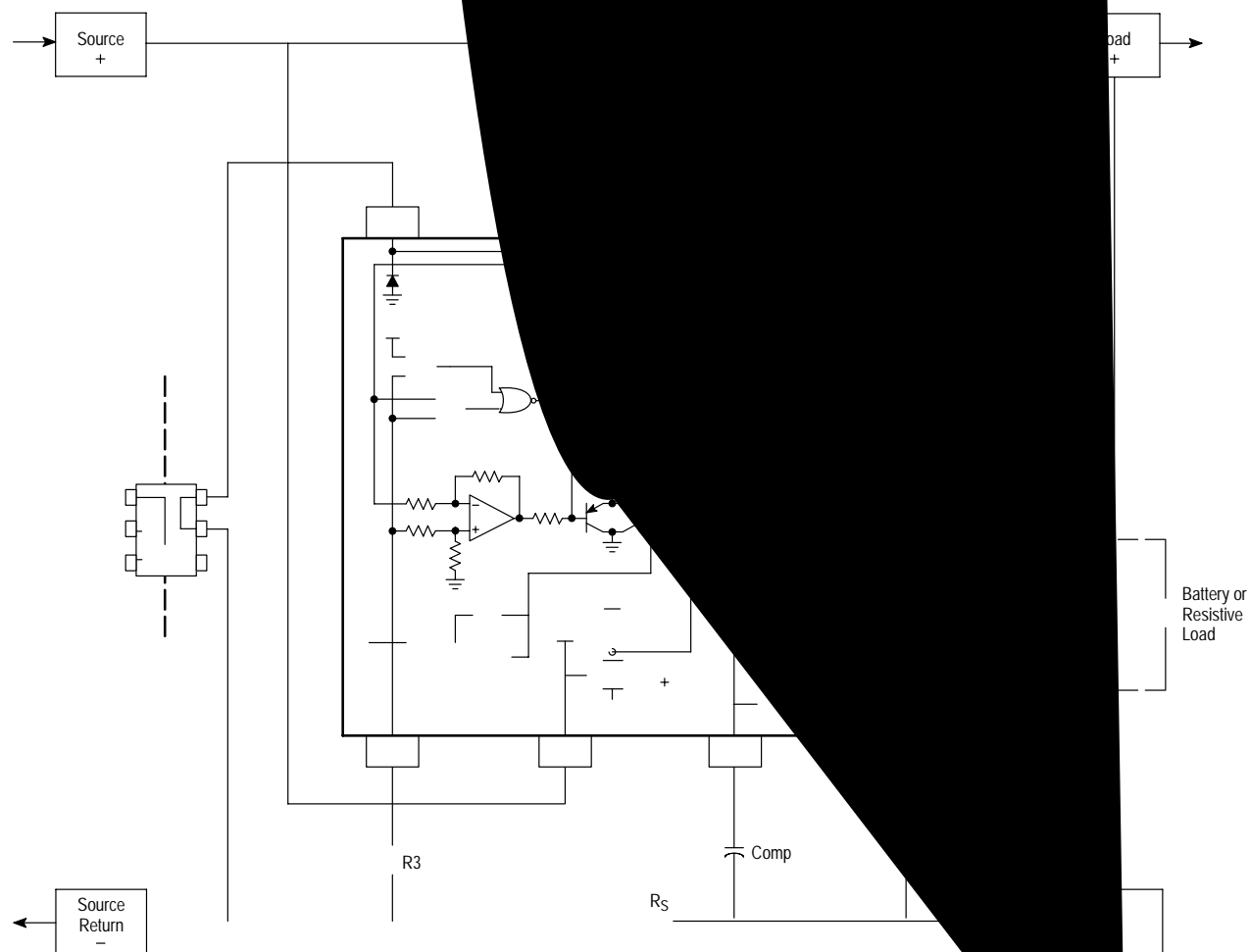

The above figure shows the MC33341 configured for source return low-side current sensing. This configuration is especially suited for negative output applications where the load is connected between Source + and Load +. This configuration is especially suited for negative output applications where the load is connected between Source + and Load +, is desired. The Inverting Amplifier inputs, Pins 1 and 4, are used to sense the load current. The voltage drop that occurs across the sense resistor R_S . The internal voltage and current regulation thresholds are selected by the respective connections of Pins 2 and 3. A sense resistor R_3 is required in applications where high peak levels of inrush current are possible. The value of R_3 should be chosen to limit the substrate current to less than 20 mA. Excessively large values for R_3 will degrade the current sensing accuracy.

MC33341

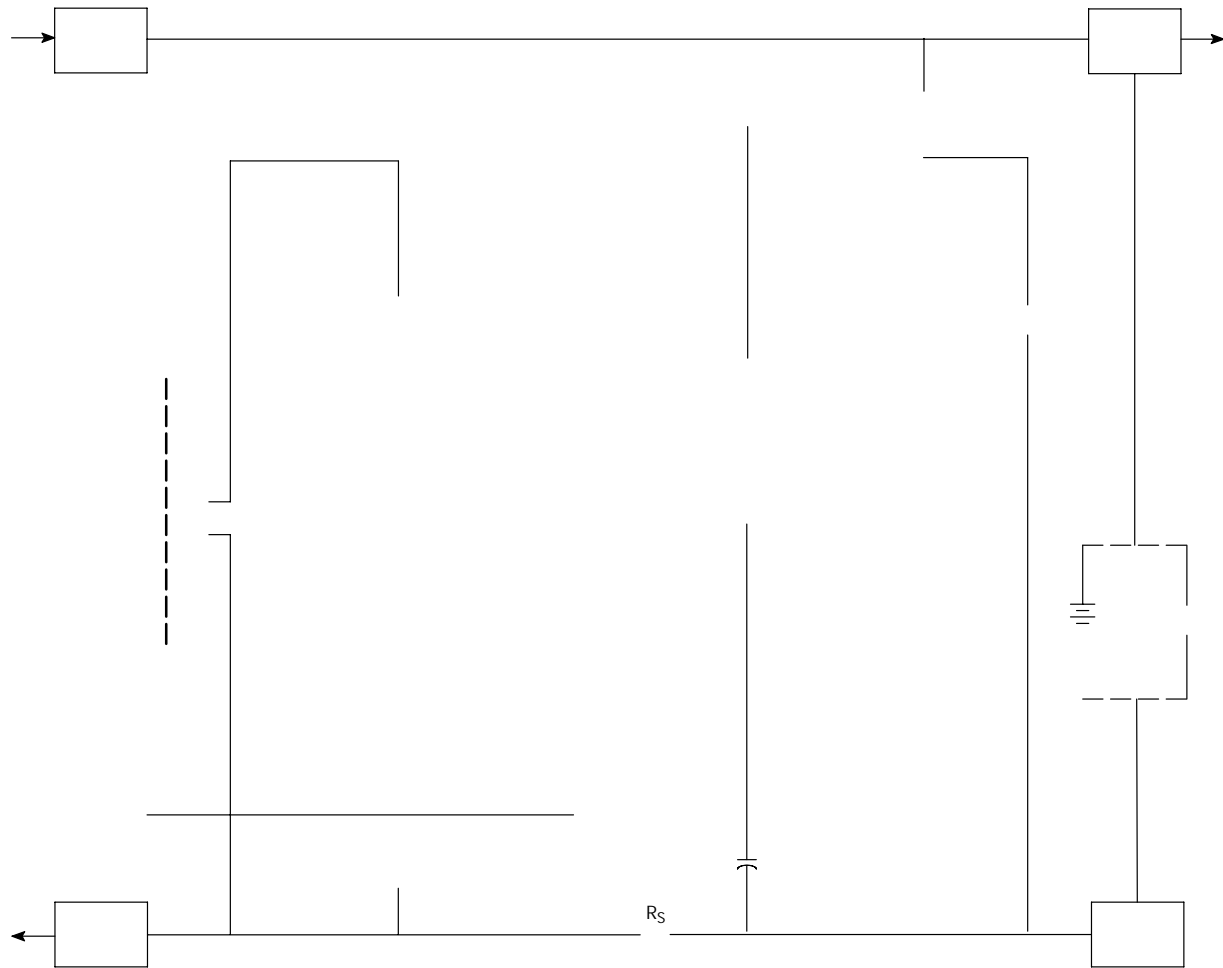

MC33341

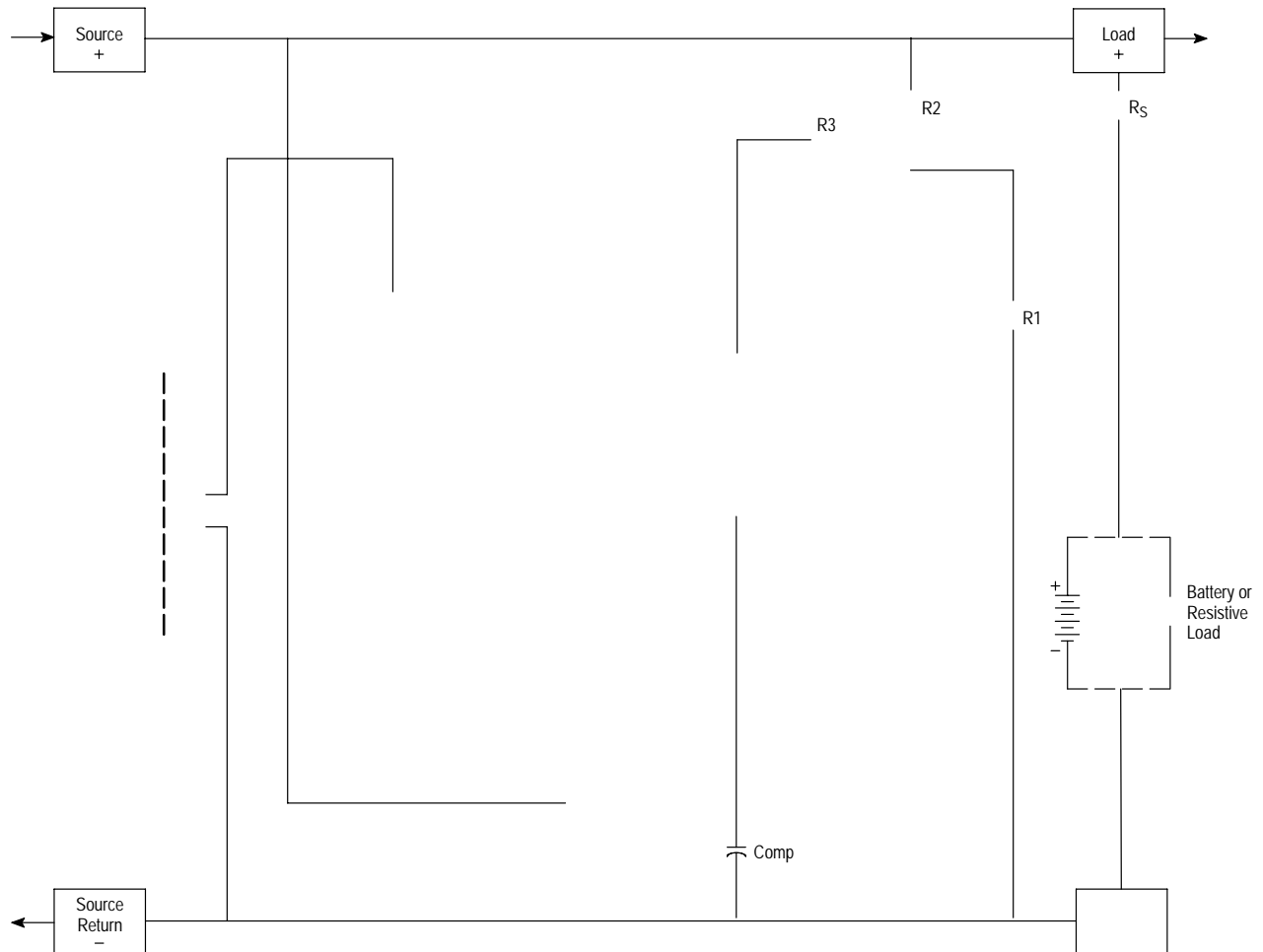

The above figure shows the MC33341 configured for load high-side current sensing allowing common paths for both power and ground, between the source and load. The Differential Amplifier inputs, Pins 1 and 6, are used to sense the load induced voltage drop that appear

MC33341

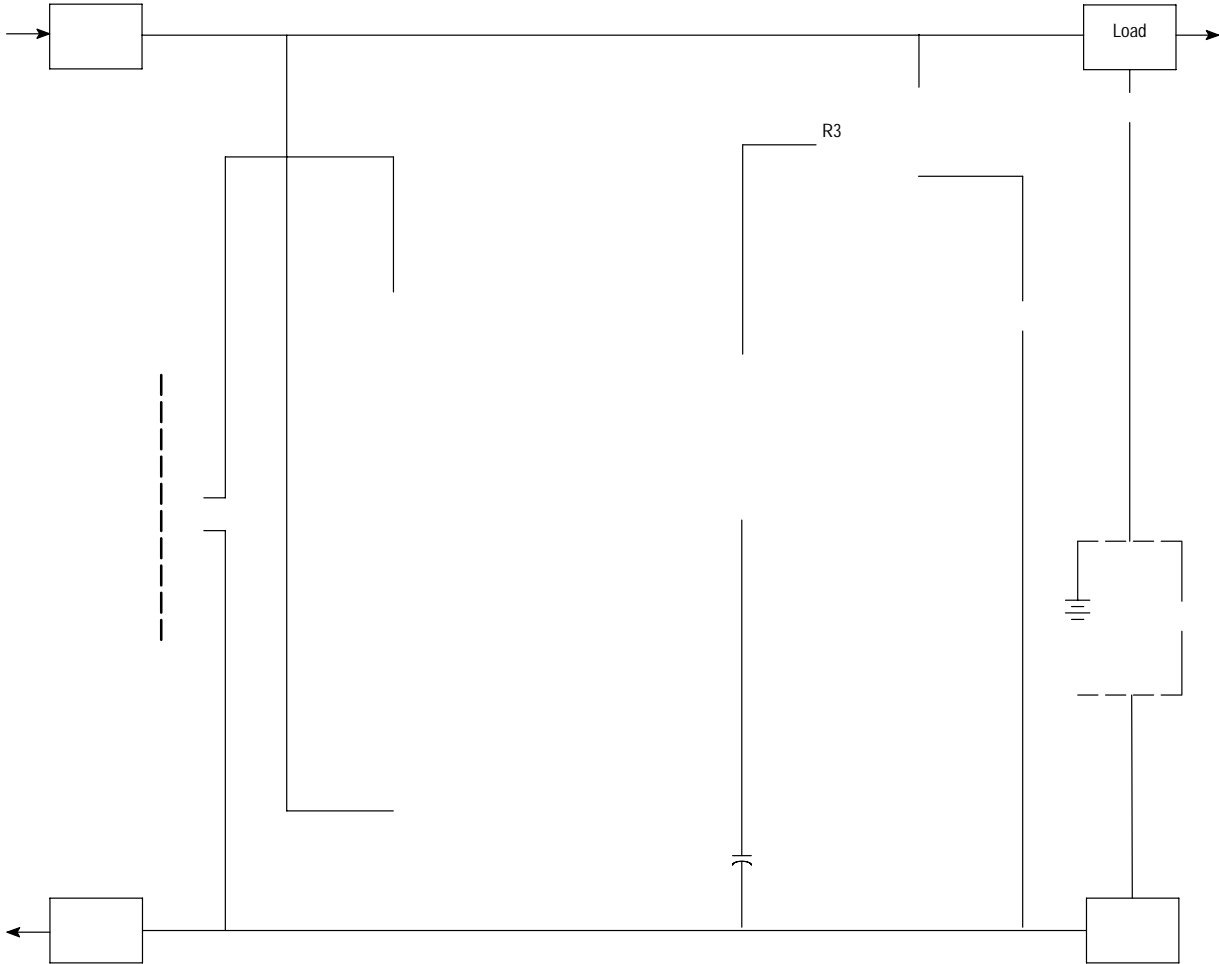

MC33341

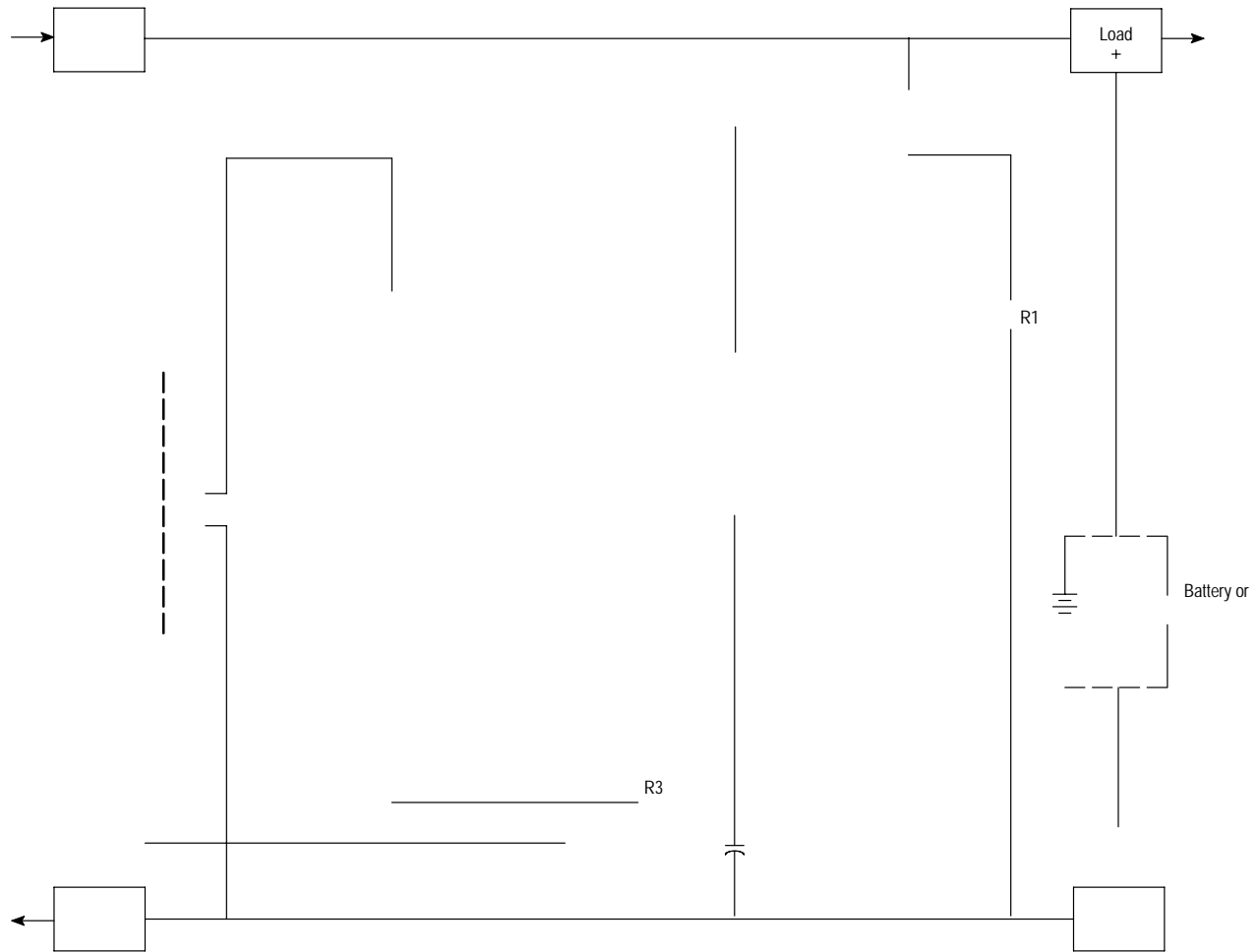
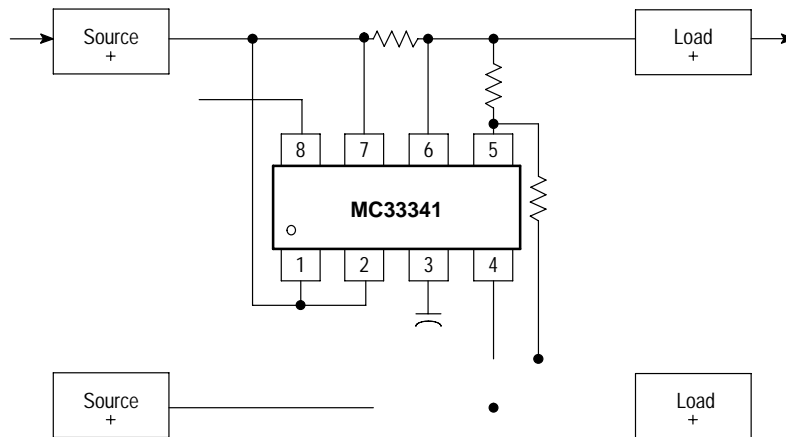



Figure 22. Current Sense Resistor Bounding



MC33341

MC33341

PDIP 8
CASE 626-05
ISSUE P

DATE 22 APR 2015

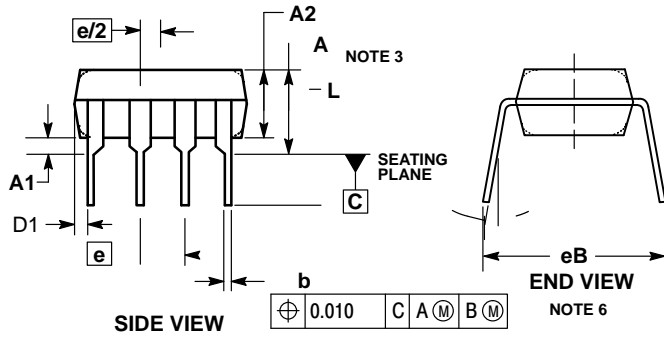
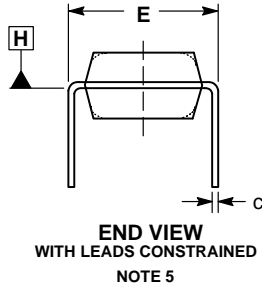
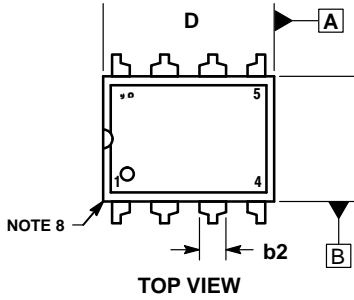

DIM	INCHES			
	MIN	MAX		
A	-----	0.210		
A1	0.015	-----		
A2	0.115	0.195	2.92	4.95
b	0.014	0.022		
C	0.008	0.014		
D	0.355	0.400		
D1	0.005	-----		
E	0.300	0.325		
e	0.100 BSC			
L	0.115	0.150	2.92	3.81

**GENERIC
MARKING DIAGRAM***

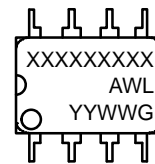

- XXXX = Specific Device Code
- A = Assembly Location
- WL = Wafer Lot
- YY = Year
- WW = Work Week
- G = Pb-Free Package

SOIC 8 NB
CASE 751-07
ISSUE AK

DATE 16 FEB 2011

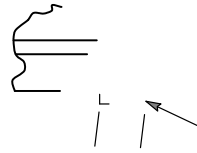
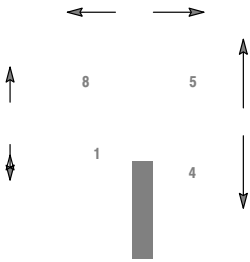

SEATING
PLANE



onsemi, **onsemi**, and other names, marks, and brands are registered and/or common law trademarks of Semiconductor Components Industries, LLC dba "**onsemi**" or its affiliates and/or subsidiaries in the United States and/or other countries. **onsemi** owns the rights to a number of patents, trademarks, copyrights, trade secrets, and other intellectual property. A listing of **onsemi**'s product/patent coverage may be accessed at www.onsemi.com/site/pdf/Patent-Marking.pdf. **onsemi** reserves the right to make changes at any time to any products or information herein, without notice. The information herein is provided "as-is" and **onsemi** makes no warranty, representation or guarantee regarding the accuracy of the information, product features, availability, functionality, or suitability of its products for any particular purpose, nor does **onsemi** assume any liability arising out of the application or use of any product or circuit, and specifically disclaims any and all liability, including without limitation special, consequential or incidental damages. Buyer is responsible for its products and applications using **onsemi**
