

**SOIC8
CASE 751DZ**

MARKING DIAGRAM

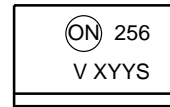

- 256 = Device Number
V = DIN EN/IEC60747-5-5 Option (only appears on component ordered with this option)
X = One-Digit Year Code, e.g., "4"
YY = Digit Work Week, Ranging from "01" to "53"
S = Assembly Package Code
-

SCHEMATIC

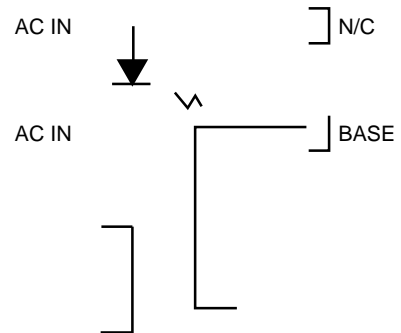

ORDERING INFORMATION

See detailed ordering and shipping information on page 5 of this data sheet.

MOC256M

SAFETY AND INSULATION RATINGS (As per DIN EN/IEC 60747-5-5, this optocoupler is suitable for “safe electrical insulation” only within the safety limit data. Compliance with the safety ratings shall be ensured by means of protective circuits.)

Parameter		Characteristics
Installation Classifications per DIN VDE 0110/1.89 Table 1, For Rated Mains Voltage	<150 V _{RMS}	I-IV
	<300 V _{RMS}	I-III
Climatic Classification		55/100/21
Pollution Degree (DIN VDE 0110/1.89)		2
Comparative Tracking Index		175

Symbol	Parameter	Value	Unit
V _{PR}	Input-to-Output Test Voltage, Method A, V _{IORM} x 1.6 = V _{PR} , Type and Sample Test with t _m = 10 s, Partial Discharge < 5 pC	904	V _{peak}
	Input-to-Output Test Voltage, Method B, V _{IORM} x 1.875 = V _{PR} , 100% Production Test with t _m = 1 s, Partial Discharge < 5 pC	1060	V _{peak}
V _{IORM}	Maximum Working Insulation Voltage	565	V _{peak}
V _{IOTM}	Highest Allowable Over-Voltage	4000	V _{peak}
	External Creepage	≥4	mm
	External Clearance	≥4	mm
DTI	Distance Through Insulation (Insulation Thickness)		

MOC256M

ELECTRICAL CHARACTERISTICS (T_A = 25°C, unless otherwise noted)

Symbol	Parameter	Test Conditions	Min	Typ	Max	Unit
--------	-----------	-----------------	-----	-----	-----	------

EMITTER

V _F	Input Forward Voltage	I _F = ±10 mA	–	1.2	1.5	V
C _{IN}	Input Capacitance	V = 0 V, f = 1 MHz	–	20	–	pF

DETECTOR

I _{CEO1}	Collector–Emitter Dark Current	V _{CE} = 10 V, T _A = 25°C	–	1.0	100	nA
I _{CEO2}		V _{CE} = 10 V, T _A = 100°C	–	1.0	–	μA
I _{CBO}	Collector–Base Dark Current	V _{CB} = 10 V	–	0.2	–	nA
BV _{CEO}	Collector–Emitter Breakdown Voltage	I _C = 10 mA	30	100	–	V
BV _{CBO}	Collector–Base Breakdown Voltage	I _C = 100 μA	70	120	–	V
BV _{ECO}	Emitter–Collector Breakdown Voltage	I _E = 100 μA	5	10	–	V
C _{CE}	Collector–Emitter Capacitance	f = 1.0 MHz, V _{CE} = 0	–	7	–	pF
C _{CB}	Collector–Base Capacitance	f = 1.0 MHz, V _{CB} = 0	–	20	–	pF
C _{EB}	Emitter–Base Capacitance	f = 1.0 MHz, V _{EB} = 0	–	10	–	pF

COUPLED

CTR	Current Transfer Ratio	I _F = ±10 mA, V _{CE} = 10 V	20	150	–	%
	Output–Collector Current Symmetry	$\left(\frac{I_C @ I_F = +10 \text{ mA}, V_{CE} = 10 \text{ V}}{I_C @ I_F = -10 \text{ mA}, V_{CE} = 10 \text{ V}} \right)$	0.5	–	2.0	
V _{CE (SAT)}	Collector–Emitter Saturation Voltage	I _C = 0.5 mA, I _F = ±10 mA	–	0.1	0.4	V

ISOLATION CHARACTERISTICS

V _{ISO}	Input–Output Isolation Voltage	t = 1 Minute	2500	–	–	V _{ACRMS}
C _{ISO}	Isolation Capacitance	V _{I-O} = 0 V, f = 1 MHz	–	0.2	–	pF
R _{ISO}	Isolation Resistance	V _{I-O} = ±500 VDC, T _A = 25°C	10 ¹¹	–	–	Ω

Product parametric performance is indicated in the Electrical Characteristics for the listed test conditions, unless otherwise noted. Product performance may not be indicated by the Electrical Characteristics if operated under different conditions.

MOC256M

TYPICAL PERFORMANCE CURVES

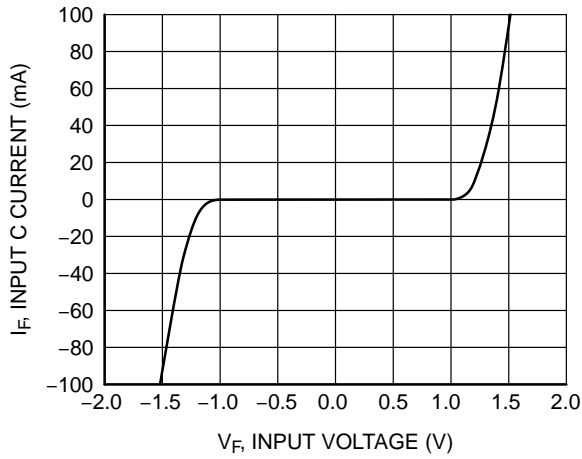

Figure 1. Input Current vs. Input Voltage

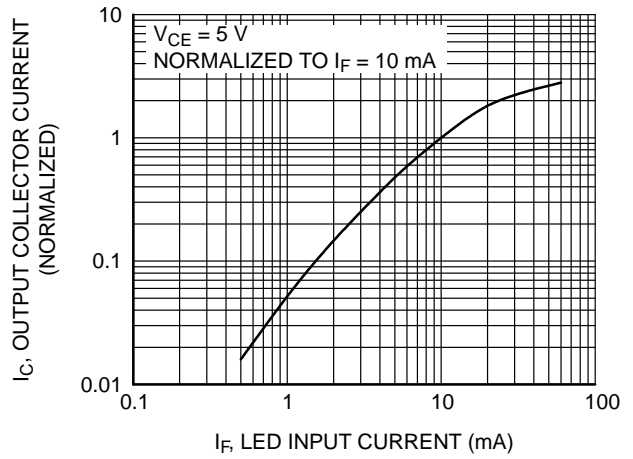

Figure 2. Output Current vs. Input Current

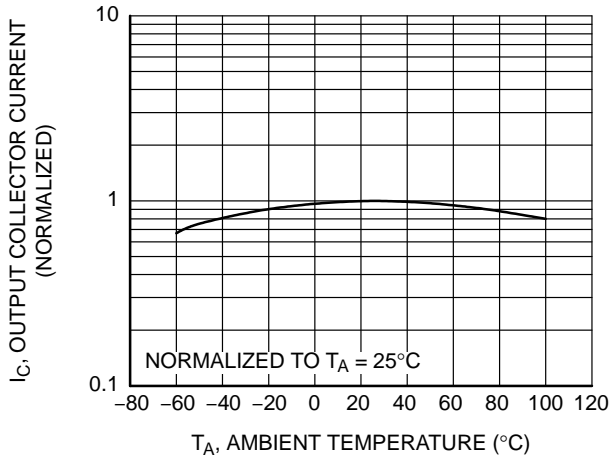

Figure 3. Output Current vs. Ambient Temperature

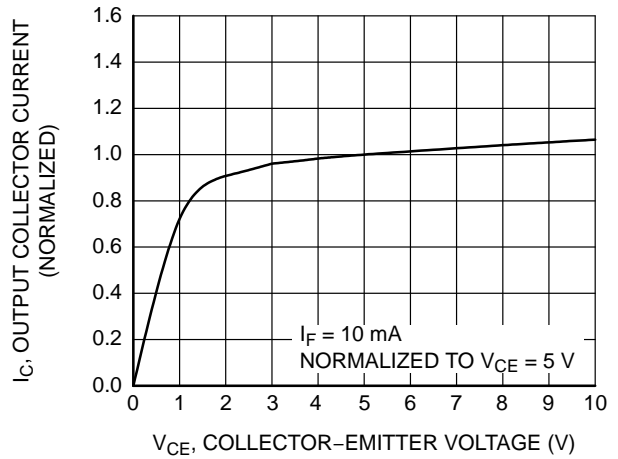

Figure 4. Output Current vs. Collector-Emitter Voltage

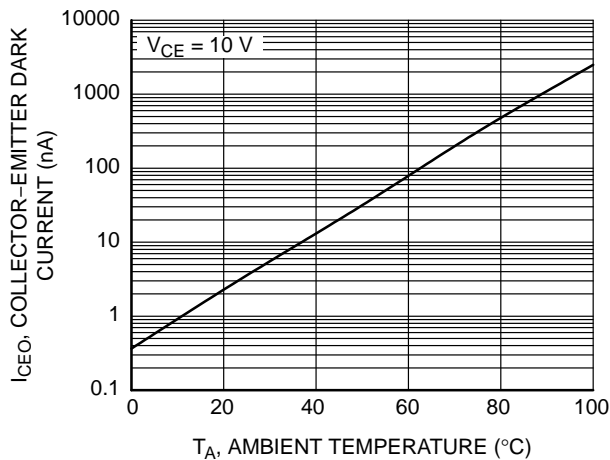
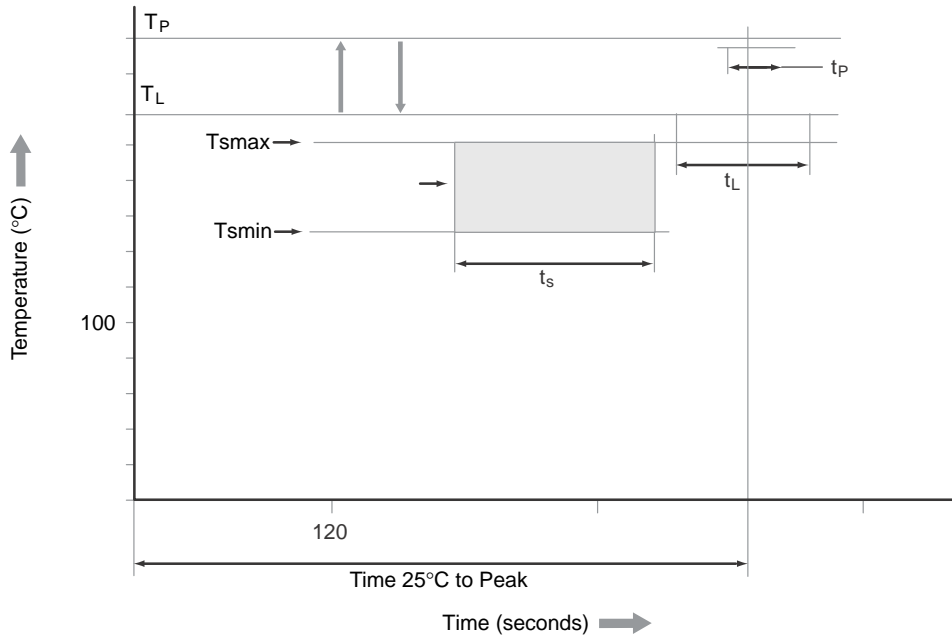
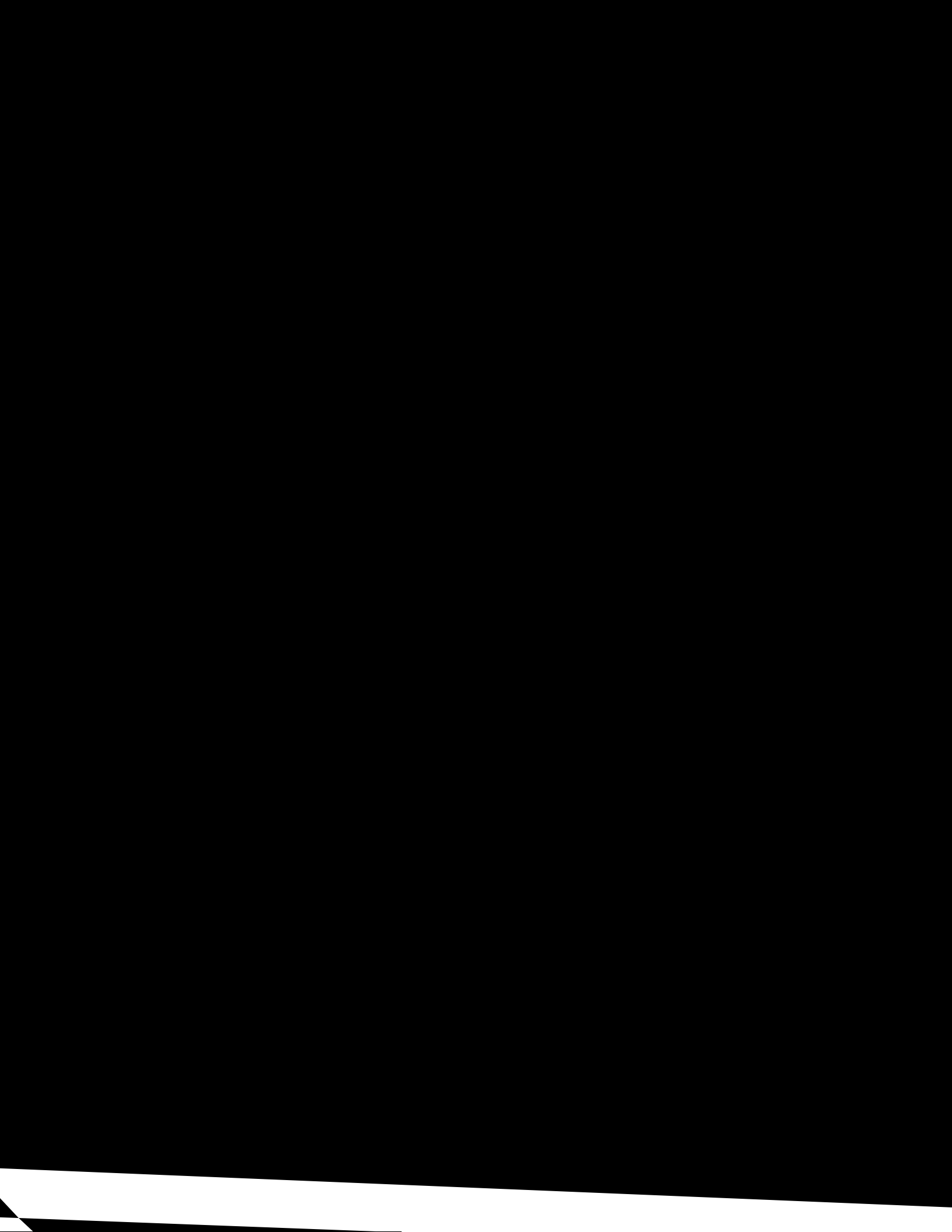

Figure 5. Dark Current vs. Ambient Temperature

MOC256M

REFLOW PROFILE





onsemi, **onsemi**, and other names, marks, and brands are registered and/or common law trademarks of Semiconductor Components Industries, LLC dba "**onsemi**" or its affiliates and/or subsidiaries in the United States and/or other countries. **onsemi** owns the rights to a number of patents, trademarks, copyrights, trade secrets, and other intellectual property. A listing of **onsemi**'s product/patent coverage may be accessed at www.onsemi.com/site/pdf/Patent-Marking.pdf. **onsemi** reserves the right to make changes at any time to any products or information herein, without notice. The information herein is provided "as-is" and **onsemi** makes no warranty, representation or guarantee regarding the accuracy of the information, product features, availability, functionality, or suitability of its products for any particular purpose, nor does **onsemi** assume any liability arising out of the application or use of any product or circuit, and specifically disclaims any and all liability, including without limitation special, consequential or incidental damages. Buyer is responsible for its products and applications using **onsemi**
