

MOC8021M, MOC8050M

Table 1. SAFETY AND INSULATION RATINGS

As per DIN EN/IEC 60747-5-5, this optocoupler is suitable for “safe electrical insulation” only within the safety limit data. Compliance with the safety ratings shall be ensured by means of protective circuits.

Parameter		Characteristics
Installation Classifications per DIN VDE 0110/1.89 Table 1, For Rated Mains Voltage	< 150 V _{RMS}	I-IV
	< 300 V _{RMS}	I-IV
Climatic Classification		55/100/21
Pollution Degree (DIN VDE 0110/1.89)		2
Comparative Tracking Index		175

Symbol	Parameter	Value	Unit
V _{PR}	Input-to-Output Test Voltage, Method A, V _{IORM} × 1.6 = V _{PR} , Type and Sample Test with t _m = 10 s, Partial Discharge < 5 pC	1360	V _{peak}
	Input-to-Output Test Voltage, Method B, V _{IORM} × 1.875 = V _{PR} , 100% Production Test with t _m = 1 s, Partial Discharge < 5 pC	1594	V _{peak}
V _{IORM}	Maximum Working Insulation Voltage	850	V _{peak}
V _{IOTM}	Highest Allowable Over-Voltage	6,000	V _{peak}

MOC8021M, MOC8050M

Table 3. ELECTRICAL CHARACTERISTICS $T_A = 25\text{ C}$ unless otherwise specified

Symbol	Parameter	Test Conditions	Min	Typ	Max	Units
EMITTER						
V_F	Input Forward Voltage	$I_F = 10\text{ mA}$		1.18	2.00	V
I_R	Reverse Leakage Current	$V_R = 3.0\text{ V}$		0.001	10	μA
DETECTOR						
BV_{CEO}	Collector–Emitter Breakdown Voltage (MOC8021M)	$I_C = 1.0\text{ mA}, I_F = 0$	50	100		V
	(MOC8050M)		80	100		V
BV_{ECO}	Emitter–Collector Breakdown Voltage	$I_E = 100\text{ }\mu\text{A}, I_F = 0$	5	10		V
I_{CEO}	Collector–Emitter Dark Current	$V_{CE} = 60\text{ V}, I_F = 0$			1	μA
C_{CE}	Capacitance	$V_{CE} = 0\text{ V}, f = 1\text{ MHz}$		8		pF

Table 4. TRANSFER CHARACTERISTICS $T_A = 25\text{ C}$ unless otherwise specified

MOC8021M, MOC8050M

TYPICAL CHARACTERISTICS

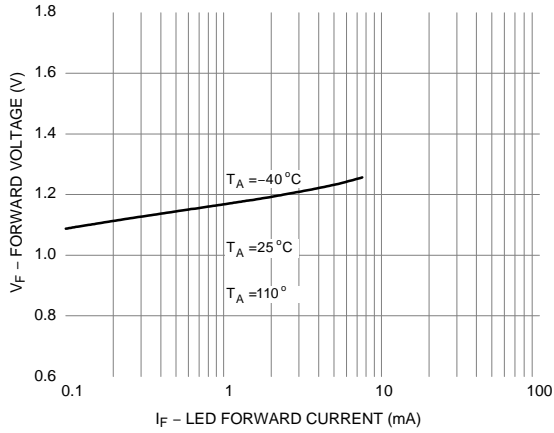

Figure 1. LED Forward Voltage vs. Forward Current

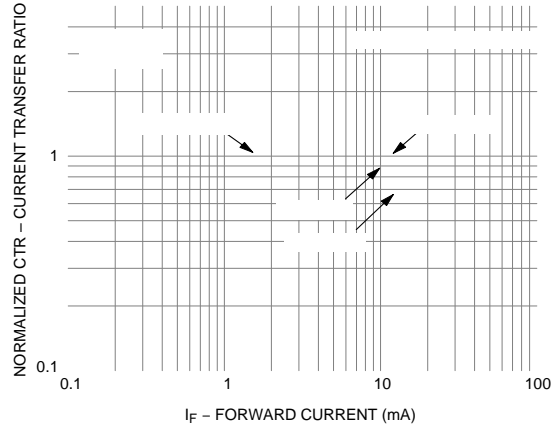

Figure 2. Normalized CTR vs. Forward Current

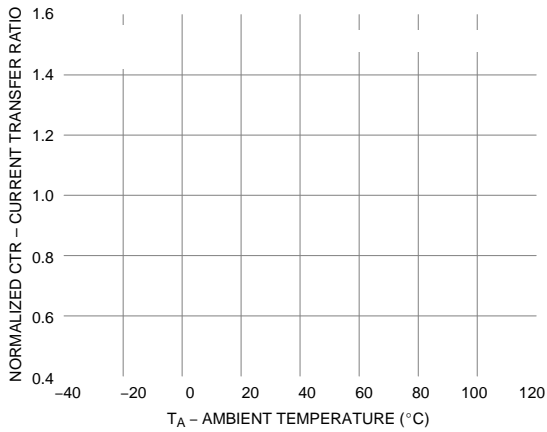

Figure 3. Normalized CTR vs. Ambient Temperature

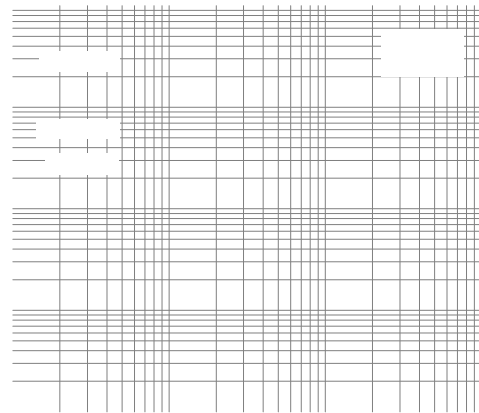

Figure 4. Turn-on Time vs. Forward Current

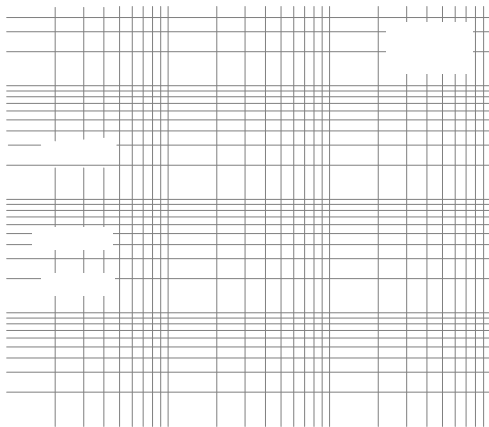

Figure 5. Turn-off Time vs. Forward Current

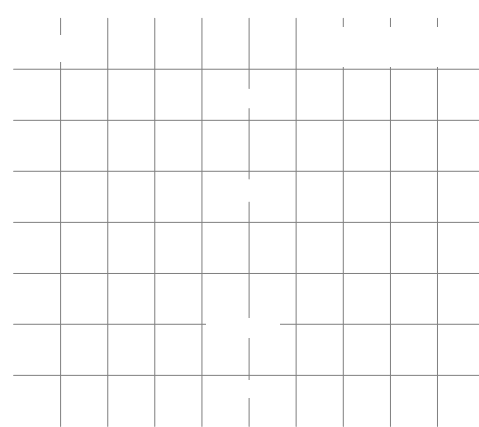

Figure 6. Normalized Collector-Emitter Current vs. Collector-Emitter Voltage

Typical Performance Curves (Continued)

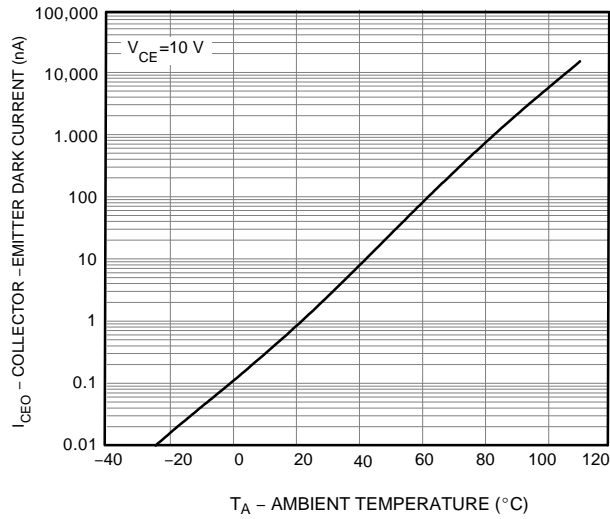

Figure 7. Dark Current vs. Ambient Temperature

Switching Time Test Circuit and Waveform

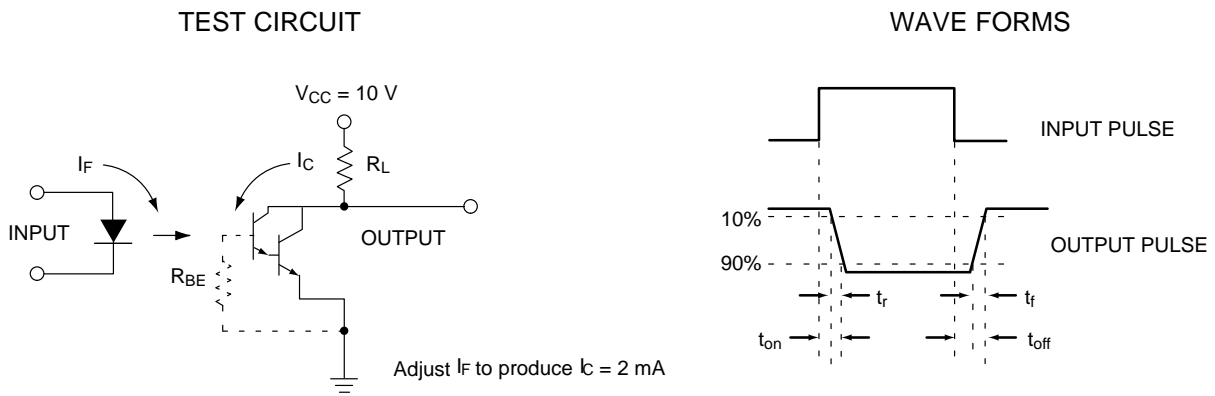
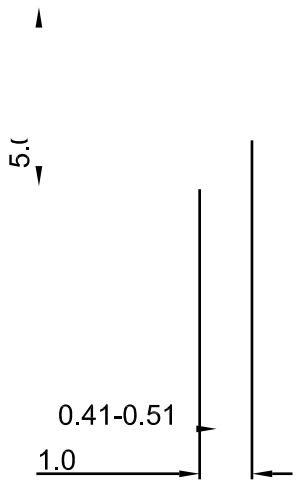

Figure 8. Switching Time Test Circuit and Waveform

MOC8021M, MOC8050M

ORDERING INFORMATION

Device Order Number	Package	Packing Method†
---------------------	---------	-----------------



SE



PDIP6 8.51x6.35, 2.54P
CASE 646BY
ISSUE A

DATE 15 JUL 2019

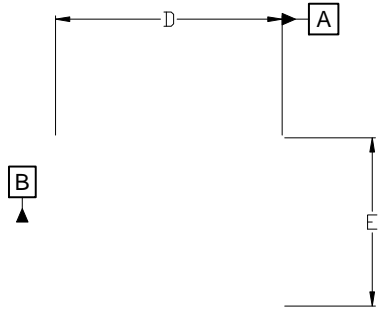

TOP VIEW

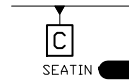

ALL DIMENSIONS ARE IN MILLIMETERS.
C) DIM ■

onsemi, **onsemi**, and other names, marks, and brands are registered and/or common law trademarks of Semiconductor Components Industries, LLC dba "**onsemi**" or its affiliates and/or subsidiaries in the United States and/or other countries. **onsemi** owns the rights to a number of patents, trademarks, copyrights, trade secrets, and other intellectual property. A listing of **onsemi**'s product/patent coverage may be accessed at www.onsemi.com/site/pdf/Patent-Marking.pdf. **onsemi** reserves the right to make changes at any time to any products or information herein, without notice. The information herein is provided "as-is" and **onsemi** makes no warranty, representation or guarantee regarding the accuracy of the information, product features, availability, functionality, or suitability of its products for any particular purpose, nor does **onsemi** assume any liability arising out of the application or use of any product or circuit, and specifically disclaims any and all liability, including without limitation special, consequential or incidental damages. Buyer is responsible for its products and applications using **onsemi**
