

# NCP2815

## NOCAP™ LongPlay Headphone Amplifier

NCP2815 is a dual LongPlay true ground headphone amplifier designed for portable communication device applications such as mobile phones. This part is capable of delivering 26 mW of continuous average power into a 32 Ω load from a 1.8 V power supply with a THD+N of 1%.

Based on the power supply delivered to the device, an internal power management block generates a symmetrical positive and negative voltage. Thus, the internal amplifiers provide outputs referenced to Ground and the losses are reduced which helps to increase the battery life. In this NOCAP configuration, the two external heavy coupling capacitors can be removed. This provides a significant space and cost savings compared to a typical stereo application.

NCP2815 is available with an external adjustable gain (version A), or internal gain of  $-1.5$  V/V (version B). It reaches a superior  $-100$  dB PSRR and noise floor. Thus, it offers high fidelity audio sound, as well as a direct connection to the battery. It contains circuitry to prevent “Pop & Click” noise that would otherwise occur during turn-on and turn-off transitions. The device is available in 12 bump CSP package (1.2 x 1.6 mm) which helps to save space on the board.

### Features

- NOCAP Output Eliminates DC-Blocking Capacitors:
  - ◆ Saves Board Area
  - ◆ Saves Component Cost
  - ◆ No Low-Frequency Response Attenuation
- LongPlay Architecture: Increase the Battery Life
- High PSRR ( $-100$  dB): Direct Connection to the Battery
- “Pop and Click” Noise Protection Circuitry
- Internal Gain ( $-1.5$  V/V) or External Adjustable Gain
- Ultra Low Current Shutdown Mode
- High Impedance Mode
- 1.6 V – 3.6 V Operation
- Thermal Overload Protection Circuitry
- CSP 1.2 x 1.6 mm
- These Devices are Pb-Free, Halogen Free/BFR Free and are RoHS Compliant

### Typical Applications

- Headset Audio Amplifier for
  - ◆ Cellular Phones
  - ◆ MP3 player
  - ◆ Personal Digital Assistant and Portable Media Player
  - ◆ Portable Devices



<http://onsemi.com>



12 PIN CSP  
FC SUFFIX  
CASE 499BJ

### MARKING DIAGRAM

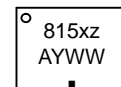

- x = A for NCP2815A  
= B for NCP2815B
- z = C for Backside laminate
- A = Assembly Location
- Y = Year
- WW = Work Week
- = Pb-Free Package

### Pin Configuration

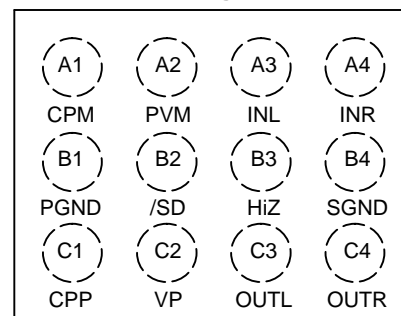

(Top View)

### ORDERING INFORMATION

See detailed ordering and shipping information on page 10 of this data sheet.

# NCP2815



Figure 1. Typical Application Circuit



# NCP2815

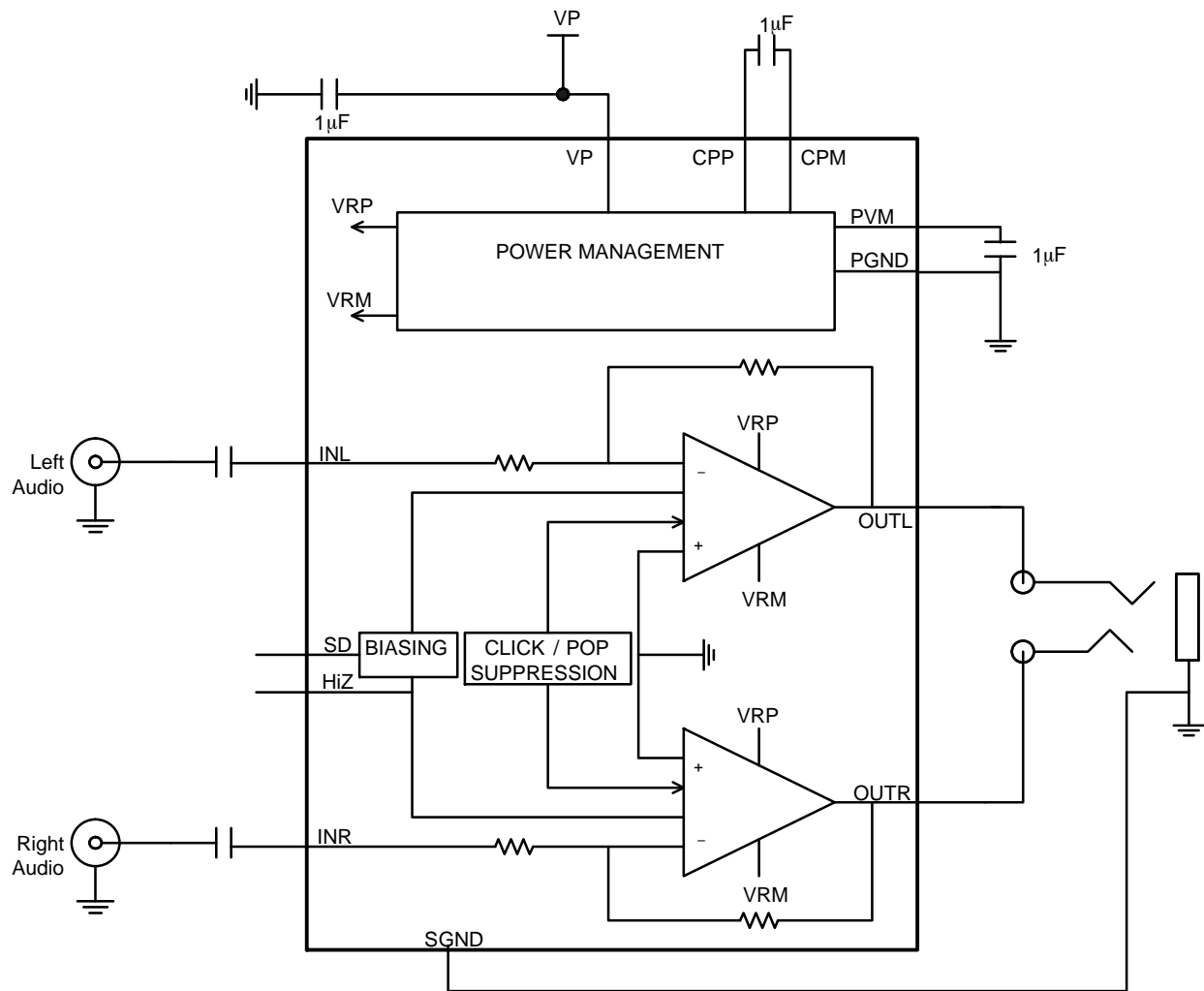

Figure 3. Typical Application Schematic Version B

## PIN FUNCTION DESCRIPTION

Pin	Pin Name	Type	Description
A1	CPM	Input / Output	Charge pump flying capacitor negative terminal. A 1 µF ceramic filtering capacitor to CPP is required
A2	PVM	Output	Charge pump output. A 1 µF ceramic filtering capacitor to ground is required
A3	INL	Input	Left input of the audio source
A4	INR	Input	Right input of the audio source
B1	PGND	Ground	Power ground
B2	/SD	Input	Enable activation.
B4	SGND	Ground	Sense Ground. Connect to shield terminal of headphone jack or ground plane.
C1	CPP	Input / Output	Charge pump flying capacitor positive terminal. A 1 µF ceramic filtering capacitor to CPM is required.
C2	VP	Power	Positive supply voltage, connected to a Lithium/Ion battery or other power supply.
C3	OUTL	Output	Left audio channel output signal
C4	OUTR	Output	Right audio channel output signal
B3	HiZ	Input	Output high impedance mode activation.

# NCP2815

## MAXIMUM RATINGS

Rating	Symbol	Value	Unit
V <sub>P</sub> Pin: Power Supply Voltage (Note 1)	V <sub>IN</sub>	-0.3 to + 4.5	V
INL, INR, /SD pins	V <sub>mr1</sub>	-0.3 to V <sub>P</sub> + 0.3	V
HiZ, OUTL, OUTR pins	V <sub>mr2</sub>	-0.3 - V <sub>P</sub> to V <sub>P</sub> + 0.3	V
Human Body Model (HBM) ESD Rating are (Note 2)	ESD HBM	2000	V
Machine Model (MM) ESD Rating are (Note 2)	ESD MM	200	V
CSP 1.2 x 1.6 mm package (Notes 6 and 7) Thermal Resistance Junction to Case	R <sub>JC</sub>	(Note 7)	°C/W
Operating Ambient Temperature Range	T <sub>A</sub>	-40 to + 85	°C
Operating Junction Temperature Range	T <sub>J</sub>	-40 to + 125	°C
Maximum Junction Temperature (Note 6)	T <sub>JMAX</sub>	+ 150	°C
Storage Temperature Range	T <sub>STG</sub>	-65 to + 150	°C
Moisture Sensitivity (Note 5)	MSL	Level 1	

## NCP2815

**ELECTRICAL CHARACTERISTICS** Min & Max Limits apply for  $T_A$  between  $-40^{\circ}\text{C}$  to  $+85^{\circ}\text{C}$  and  $T_J$  up to  $+125^{\circ}\text{C}$  for  $V_{IN}$  between 1.6 V to 3.6 V (Unless otherwise noted). Typical values are referenced to  $T_A = +25^{\circ}\text{C}$  and  $V_P = 1.8\text{ V}$ .

Symbol	Parameter	Conditions	Min	Typ	Max	Unit
$V_{BAT}$	Supply voltage range		1.6		3.6	V
$I_{SD}$	Shutdown current				1	$\mu\text{A}$
$I_Q$	Quiescent current	$V_P = 1.8\text{ V}$		1.6	2.2	mA
$R_{IN}$	Input resistance		15	20	25	$\text{k}\Omega$
$R_{SD}$	/SD pull-down resistor			300		$\text{k}\Omega$
$R_{HiZ}$	HiZ pull-down resistor			150		$\text{k}\Omega$
	Maximum input signal swing			2.8		$V_{P-P}$
$V_{IH}$	High-level input voltage SD and HiZ pin		1.2			V
$V_{IL}$	Low-level input voltage SD and HiZ pin				0.4	V
UVLO	UVLO threshold	Falling edge		1.4		V
UVLO <sub>HYS</sub>	UVLO hysteresis			100		mV
$T_{SD}$	Thermal shutdown temperature			160		$^{\circ}\text{C}$
$V_{OS}$	Output offset voltage	Input AC grounded		$\pm 0.5$		

# NCP2815

## TYPICAL OPERATING CHARACTERISTICS

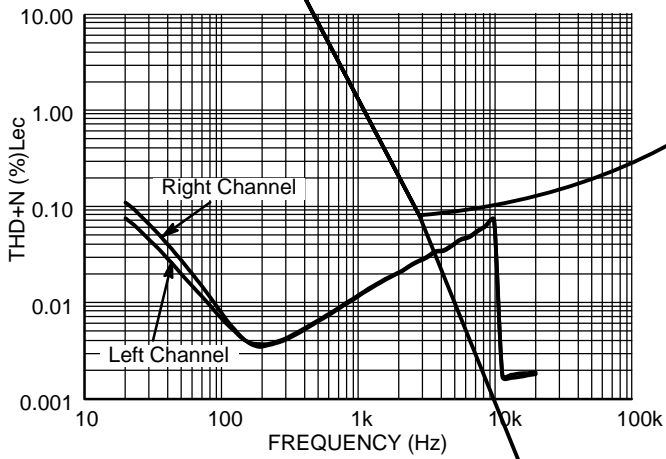

Figure 4. THD+N vs Frequency in Phase, 32  $\Omega$  Load,  $P_{out} = 10$  mW

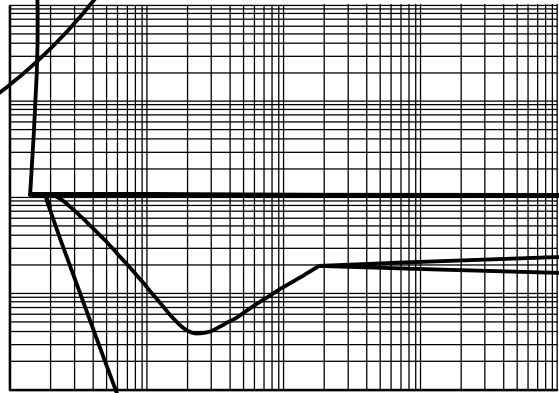

Figure 5. THD+N vs Frequency in Phase, 32  $\Omega$  Load,  $P_{out} = 10$  mW



Figure 6. THD+N vs  $P_{out}$ , 32  $\Omega$  Load

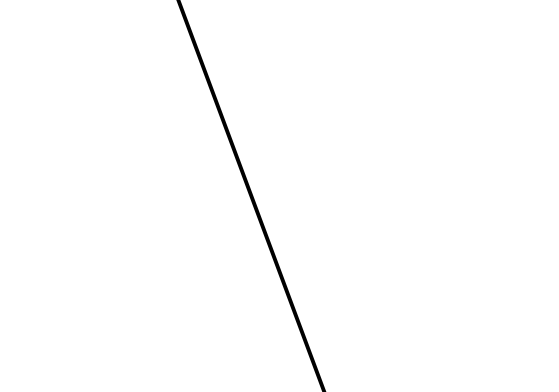

Figure 7. THD+N vs  $P_{out}$ , 16  $\Omega$  Load

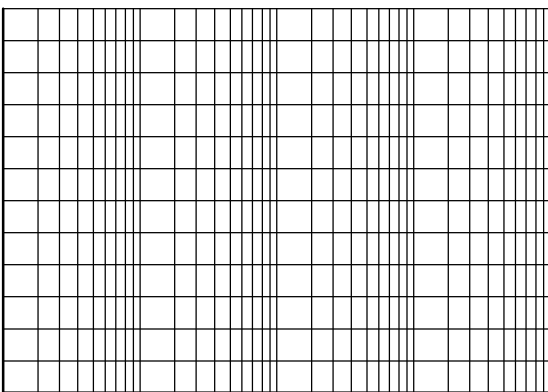

Figure 8. Power Supply Rejection Ratio vs. Frequency

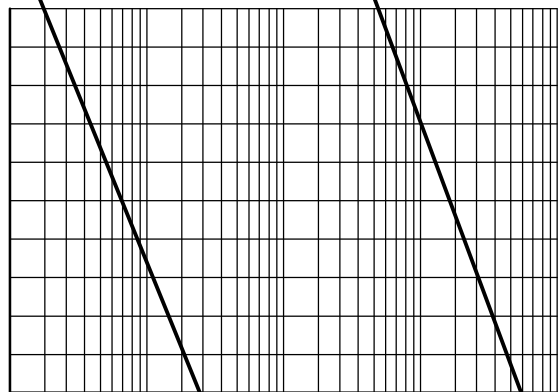

Figure 9. Crosstalk vs. Frequency,  $R_{load} = 32 \Omega$ ,  $P_{out} = 10$  mW





## DETAIL OPERATING DESCRIPTION

### Detailed Description

The NCP2815 is a stereo headphone amplifier with NOCAP architecture. This architecture eliminates the need to use two big external capacitors required by conventional headphone amplifier.

The structure of the NCP2815 is composed of two true ground amplifiers, a UVLO, a short circuit protection and a thermal shutdown circuit. Additionally, a special circuit is embedded to eliminate any pop and click noise that occurs during turn on and turn off time. Version A has an external gain selectable by two resistors, Version B has a gain of 1.5 V/V.

### NOCAP

NOCAP is a patented architecture which requires only 2 small ceramic capacitors. It generates a symmetrical positive and negative voltage which it allows the output of the amplifiers to be biased to ground.

### LongPlay Architecture

NCP2815 includes a LongPlay architecture which helps to save battery life by reducing the quiescent current. The charge pump frequency is reduced to 125 kHz for an output load < 500  $\mu$ W.

### Current Limit Protection Circuit

The NCP2815 contains protection circuitry against shorts to ground. The current is limited to 300 mA when an output is shorted to GND and a signal appears at the input.

### Thermal Overload Protection

Internal amplifiers are switched off when the temperature exceeds 160°C, and are switched back on when the temperature decreases below 140°C.

### Under Voltage Lockout

When the battery voltage decreases below 1.4 V, the amplifiers are turned off. The hysteresis required to turn back on the device is 100 mV.

### Pop and Click Suppression Circuitry

The NCP2815 includes a special circuit to eliminate any

# NCP2815

## ORDERING INFORMATION

Device	Package	Shipping†
NCP2815AFCT2G	CSP – 12 – 1.6 x 1.2 mm (Pb-Free)	3000 / Tape & Reel
NCP2815BFCT2G	CSP – 12 – 1.6 x 1.2 mm (Pb-Free)	3000 / Tape & Reel
NCP2815BFCCT2G	CSP – 12 – 1.6 x 1.2 mm (Backside laminate coating) (Pb-Free)	3000 / Tape & Reel

†For information on tape and reel specifications, including part orientation and tape sizes, please refer to our Tape and Reel Packaging Specifications Brochure, BRD8011/D.

**WLCSP12 1.62x1.22x0.539**

CASE 499BJ

ISSUE D

NOTES:

DATE 02 JUN 2022

1. DIMENSIONING AND TOLERANCING PER

2. CONTROLLING DIMENSION: MILLIMETERS
3. DIMENSION b IS MEASURED AT THE MAXIMUM SOLDER BALL DIAMETER PARALLEL TO DATUM C.
4. COPLANARITY APPLIES TO THE SPHERICAL CROWNS OF THE SOLDER BALLS.
5. DATUM C, THE SEATING PLANE, IS DEFINED BY THE SPHERICAL CROWNS OF THE SOLDER BALLS.

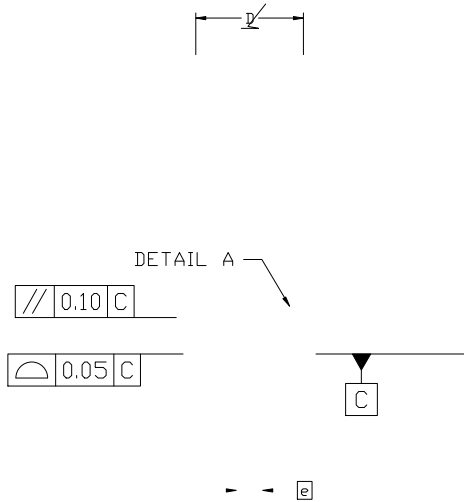

0.295	0.320	MAX. 0.594 0.224 0.345 0.299
-------	-------	--

DETAIL A  
SCALE 1:3

A1

**GENERIC MARKING DIAGRAM\***

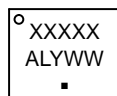

- XXXXX = Specific Device Code
- A = Assembly Location
- L = Wafer Lot
- Y = Year
- WW = Work Week
- = Pb-Free Package

This information is generic. Please refer to the device data sheet for actual part marking. The Pb-Free indicator, "G" or microdot "▪", may or may not be present. Some products may not follow the Generic Marking.

**RECOMMENDED MOUNTING**



\* For additional information, see SOLDERM/D.

**onsemi**, **onsemi**, and other names, marks, and brands are registered and/or common law trademarks of Semiconductor Components Industries, LLC dba "**onsemi**" or its affiliates and/or subsidiaries in the United States and/or other countries. **onsemi** owns the rights to a number of patents, trademarks, copyrights, trade secrets, and other intellectual property. A listing of **onsemi**'s product/patent coverage may be accessed at [www.onsemi.com/site/pdf/Patent-Marking.pdf](http://www.onsemi.com/site/pdf/Patent-Marking.pdf). **onsemi** reserves the right to make changes at any time to any products or information herein, without notice. The information herein is provided "as-is" and **onsemi** makes no warranty, representation or guarantee regarding the accuracy of the information, product features, availability, functionality, or suitability of its products for any particular purpose, nor does **onsemi** assume any liability arising out of the application or use of any product or circuit, and specifically disclaims any and all liability, including without limitation special, consequential or incidental damages. Buyer is responsible for its products and applications using **onsemi**

---

---