

NCS2211, NCV2211

Low Distortion Audio Power Amplifier with Differential Output and Shutdown Mode

Product Description

The NCS2211 is a high performance, low distortion Class A/B audio amplifier. It is capable of delivering 1 W of output power into an 8 Ω speaker bridge-tied load (BTL). The NCS2211 will operate over a wide temperature range, and it is specified for single-supply voltage operation for portable applications.

It features low distortion performance, 0.2% typical THD + N @ 1 W and incorporates a shutdown/enable feature to extend battery life. The shutdown/enable feature will reduce the quiescent current to 1 μ A maximum.

The NCS2211 is designed to operate over the -40°C to $+85^{\circ}\text{C}$ temperature range, and is available in an 8-lead SOIC package and a 3 X 3 mm DFN8 package. The SOIC package is pin compatible with equivalent function and comparable performance to competitive devices as is the DFN8 package. The DFN8 has a low thermal resistance of only $70^{\circ}\text{C}/\text{W}$ plus has an exposed metal pad to facilitate heat conduction to copper PCB material.

Low distortion, high power, low quiescent current, and small packaging makes the NCS2211 suitable for applications including notebook and desktop computers, PDA's, and speaker phones.

Features

- Differential Output
- 1.0 W into an 8 Ω Speaker
- 1.5 W into a 4 Ω Speaker
- Single Supply Operation: 2.7 V to 5.5 V
- THD+N: 0.2% @ 1 W Output
- Low Quiescent Current: 20 mA Max
- Shutdown Current < 1.0 μ A
- Excellent Power Supply Rejection
- Two Package Options: SOIC-8 Package and DFN8
- Pin Compatible with Competitive Devices
- NCV Prefix for Automotive and Other Applications Requiring Unique Site and Control Change Requirements; AEC-Q100 Qualified and PPAP Capable
- These Devices are Pb-Free, Halogen Free/BFR Free and are RoHS Compliant

Applications

- Desktop Computers
- Notebook Computers
- PDA's
- Speaker Phones
- Games

NCS2211, NCV2211

PIN CONNECTIONS for SOIC-8 and DFN8

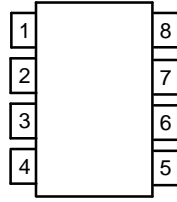

NCS2211, NCV2211

TYPICAL PERFORMANCE CHARACTERISTICS

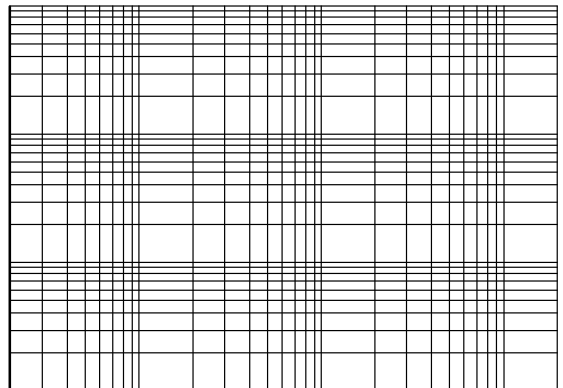
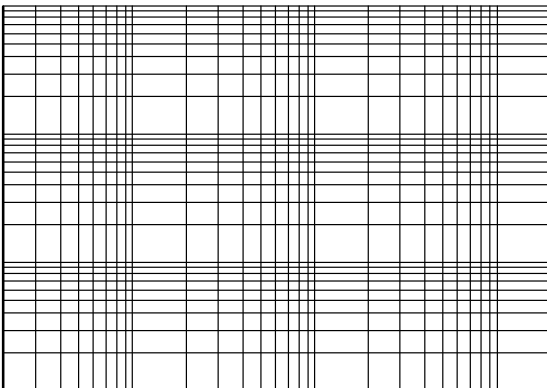
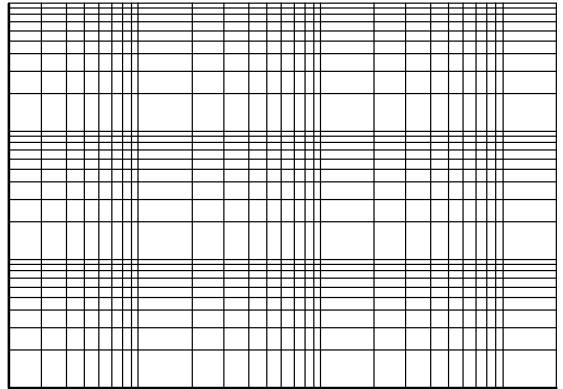

NCS2211, NCV2211

TYPICAL PERFORMANCE CHARACTERISTICS

Figure 20. Turn-on Time

Figure 21. Turn-off Time

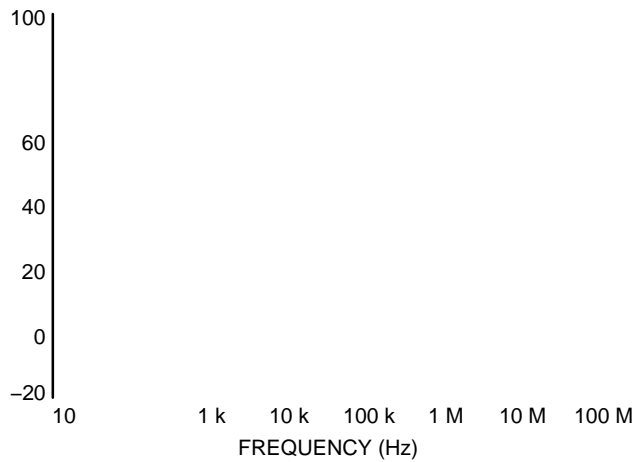

Figure 22. Gain and Phase Shift vs. Frequency

NCS2211, NCV2211

TYPICAL PERFORMANCE CHARACTERISTICS

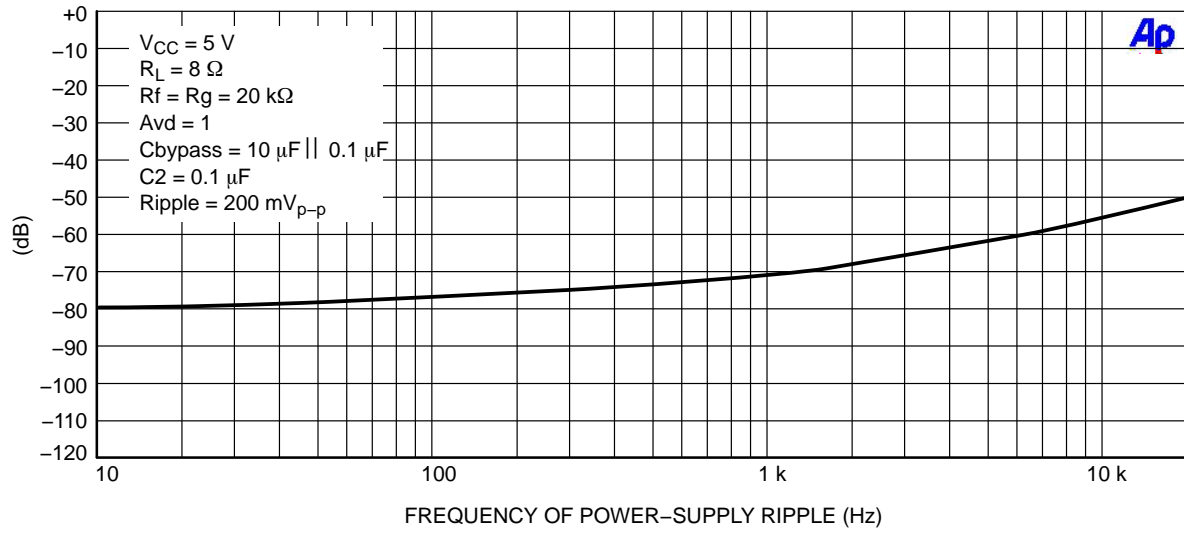

Figure 23. Power-Supply Rejection

NCS2211, NCV2211

APPLICATIONS INFORMATION

The NCS2211 is unity gain stable and therefore does not require any compensation, but a proper power-supply bypass is required as shown in Figure 24. Performance will be enhanced by adding a filter capacitor (C2) to the mid-supply node (pin 2). See Typical Performance Characteristics for details.

It is preferable to AC couple the input to avoid a large DC output offset.

Both outputs can be driven to within 400 mV of either supply rail with an 8 Ω load.

Typical Application of the Device:

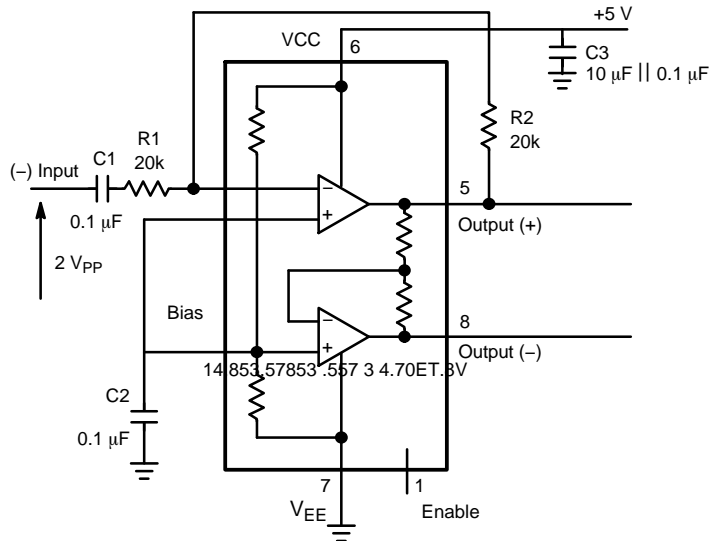

Figure 24.

MECHANICAL CASE OUTLINE

PACKAGE DIMENSIONS

ON Semi



DFN8 3x3, 0.5P
CASE 506BJ-01
ISSUE O

DATE 08 NOV 2007

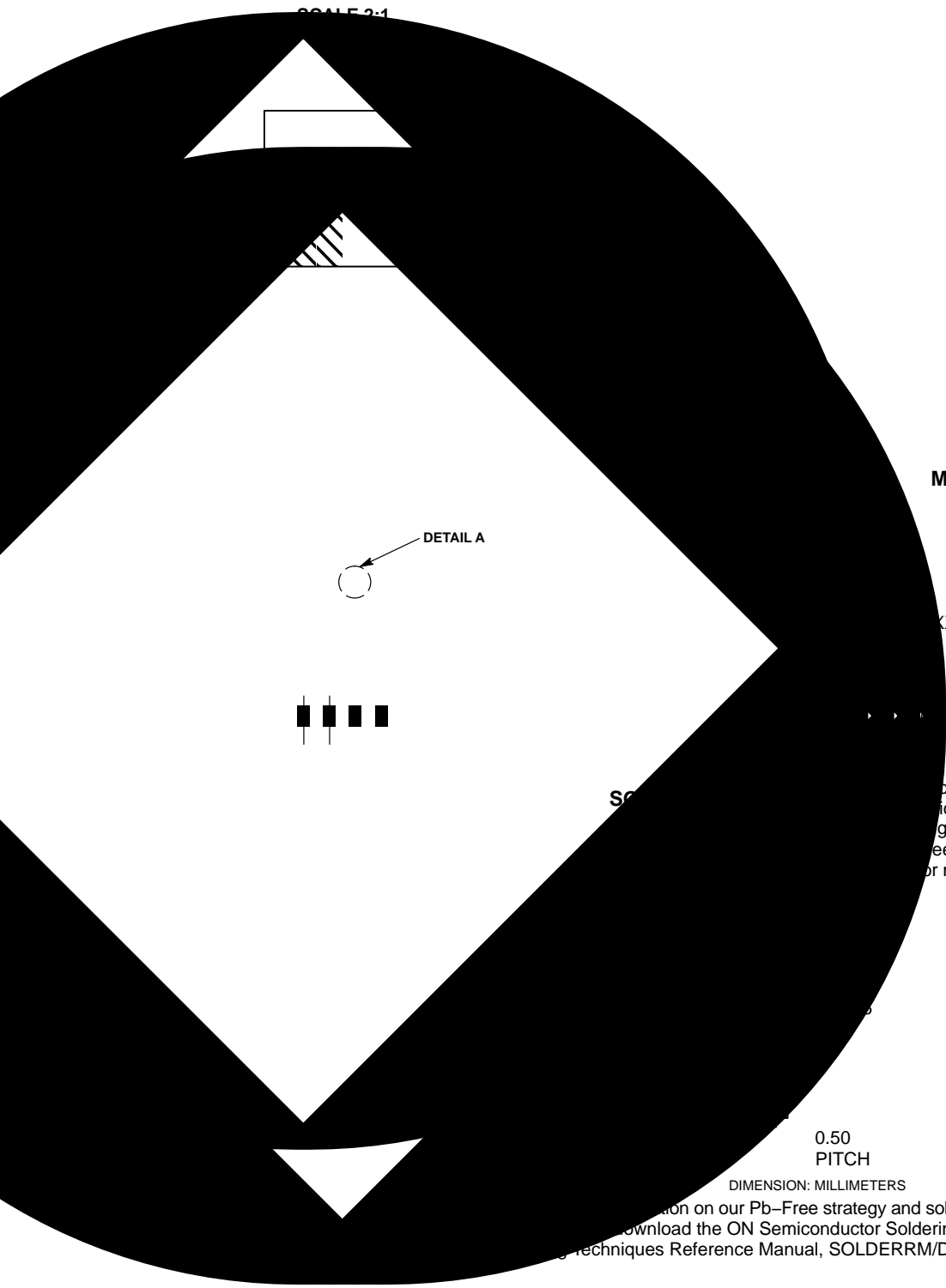

SCALE 2:1

DETAIL A

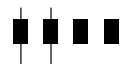

SO

GENERIC MARKING DIAGRAM*

○ 8

- XXX = Specific Device Code
- = Assembly Location
- = Wafer Lot
- = Year
- = Work Week
- = Pb-Free Package

(microdot may be in either location)
Information is generic. Please refer to the device data sheet for actual part marking.
The "G" or microdot "▪", or "Pb-Free" indicator, "G" or microdot "▪", or "Pb-Free" indicator may not be present.

0.50
PITCH

DIMENSION: MILLIMETERS

For more information on our Pb-Free strategy and soldering techniques, please visit our website or download the ON Semiconductor Soldering and Mounting Techniques Reference Manual, SOLDERRM/D.

SOIC-8 NB

-

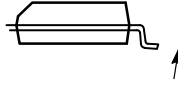
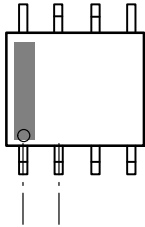

SOIC-8 NB

-

-
-
-
-
-
-
-

DOCUMENT NUMBER:	98ASB42564B	
DESCRIPTION:	SOIC-8 NB	PAGE 2 OF 2

ON
