

NCS2632

NOCAP™, Pop-Free, 3 V_{RMS} Audio Line Driver with Adjustable Gain

The NCS2632 is a pop-free stereo line driver. It uses ON Semiconductor's patented NOCAP technology which allows the elimination of the external DC-blocking capacitors by providing ground-referenced outputs through the generation of an internal negative supply rail. The device can drive 3 V_{RMS} into a 600 Ω load at 5 V power supply. By eliminating the two external heavy coupling capacitors, the NOCAP approach offers significant space and cost savings compared to similar audio solutions.

The NCS2632 has differential inputs and is available with an external adjustable gain ranging from ±1 V/V to ±10 V/V. The gain is adjusted with external resistors. The device can also be configured as a 2nd order low pass filter to complement DAC's and SOC converters. In addition to the NOCAP architecture, it contains specific circuitry to prevent "Pop & Click" noise from occurring during Enable / Shutdown transitions. The Signal-to-Noise Ratio reaches 105 dB, offering high fidelity audio sound. The NCS2632 exhibits a high power supply rejection with a typical value of 90 dB. This device also features an Under-Voltage Protection (UVP) function which can be adjusted using an external resistor bridge. The device is available in a TSSOP-14 package.

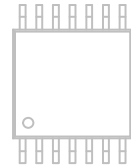

1 Features

- NOCAP
 - ◆ Eliminates Pop/Clicks
 - ◆ ~~NO CAP~~

1

NCS2632

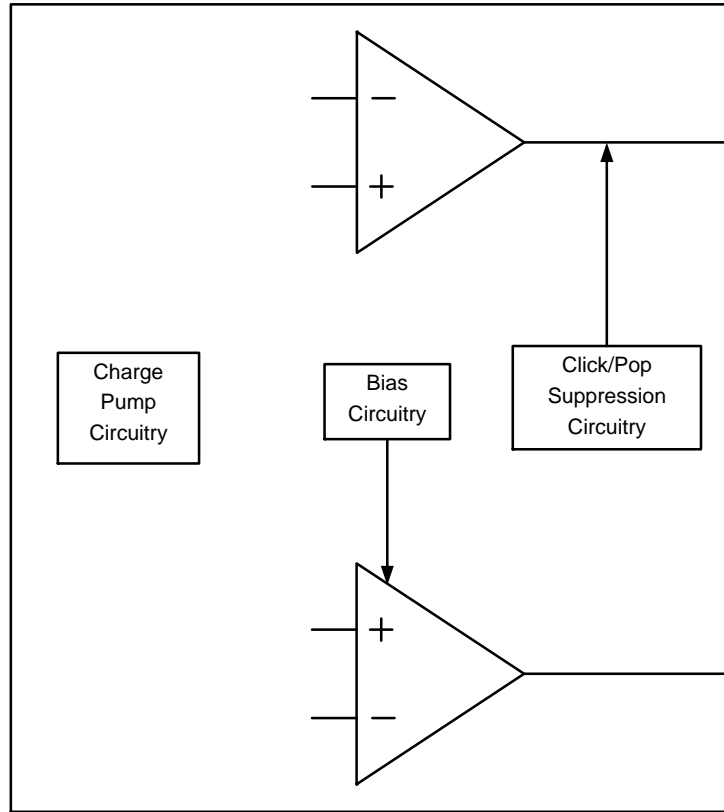

NCS2632

PIN FUNCTION AND DESCRIPTION

Pin	Name
-----	------

NCS2632

ELECTRICAL CHARACTERISTICS, $T_A = 25^\circ\text{C}$ (unless otherwise noted)

Parameter	Symbol	Test Conditions	Min	Typ	Max	Unit
Output Offset Voltage	$ V_{OS} $	$V_{DD} = 2.5\text{ V to }5\text{ V}$, Voltage follower – gain = 1		100	400	V
High-Level Input Current (EN)	$ I_{IH} $	$V_{DD} = 5\text{ V}$, $V_I = V_{DD}$			100	nA
Low-Level Input Current (EN)	$ I_{IL} $	$V_{DD} = 5\text{ V}$, $V_I = 0\text{ V}$			100	nA
Supply Current	I					

NCS2632

TYPICAL CHARACTERISTICS

$V_{DD} = 3.3\text{ V}$, $T_A = 25^\circ\text{C}$, $R_L = 2.5\text{ k}\Omega$, $C_{VSS} = 1\text{ F}$, $C_{IN} = 10\text{ F}$, $R_{IN} = 10\text{ k}\Omega$, $R_{fb} = 20\text{ k}\Omega$ (unless otherwise noted)

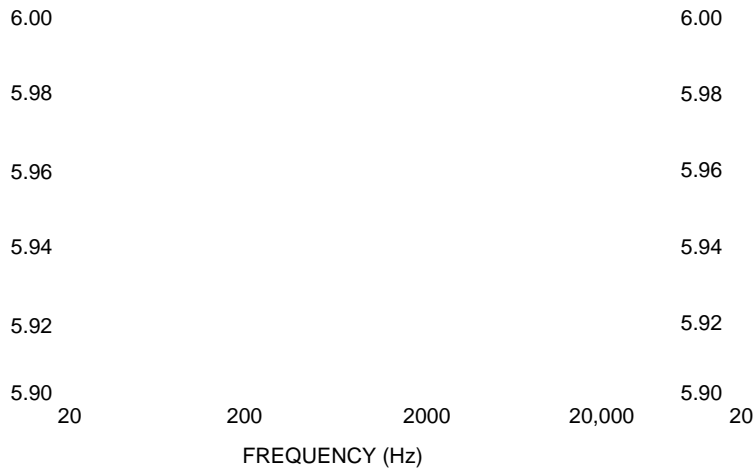

**Figure 9. Gain vs. Frequency,
 $R_L = 2.5\text{ k}\Omega$**

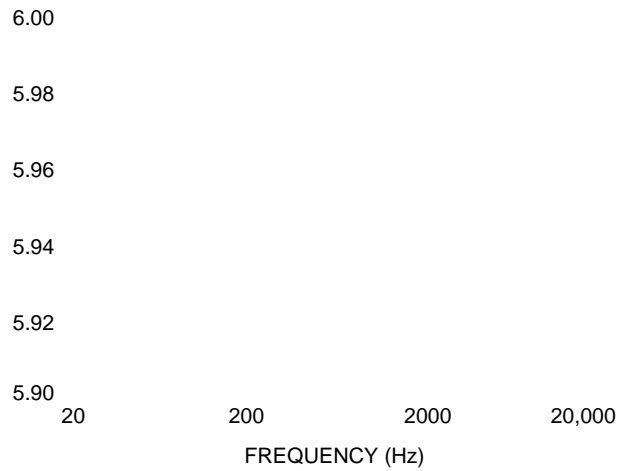

**Figure 10. Gain vs. Frequency,
 $R_L = 600\ \Omega$**

**Figure 11. Crosstalk vs. Frequency,
 $R_L = 2.5\text{ k}\Omega$, $V_{DD} = 3.3\text{ V}$, V_O**

NCS2632

APPLICATION INFORMATION

DESCRIPTION

The NCS2632 is a stereo line driver with a NOCAP architecture. This architecture eliminates the need to use two large, external capacitors required by conventional audio line driver applications. The NCS2632 is basically composed of two true ground amplifiers with internal power supply rail, one UVP-circuit block, and short-circuit protection. The gain of the NCS2632 can be adjusted with two external resistors.

The NOCAP approach is a patented architecture that requires only two 1 F low ESR ceramic capacitors (fly capacitor and reservoir capacitor). It generates a symmetrical positive and negative voltage and it allows the output of the amplifiers to be biased around the ground (True Ground).

The NCS2632 includes a special circuitry for eliminating any pop and click noise during turn on and turn off time. This circuitry combined with the true ground output architecture and a trimmed output offset voltage makes the elimination of pop and click particularly efficient.

UNDER-VOLTAGE PROTECTION (UVP) PIN MANAGEMENT

The UVP pin can be used to shut down the audio line driver by monitoring the board's main power supply. Then the line driver can be shut down before upstream devices

disable, contributing this way to eliminate potential source of pop noise.

The device shuts down when the UVP voltage goes below 1.25 V typically. To monitor the lower main power supply limit, an external voltage divider constituted with three resistors, RUP, RDW and RHYS is used (Figure 21). Resistors values have to be chosen based on the requested power supply shutdown threshold and hysteresis for a given application. It is recommended to have $RHYS \gg RDW // RUP$. RHYS is optional in the case where hysteresis is not necessary.

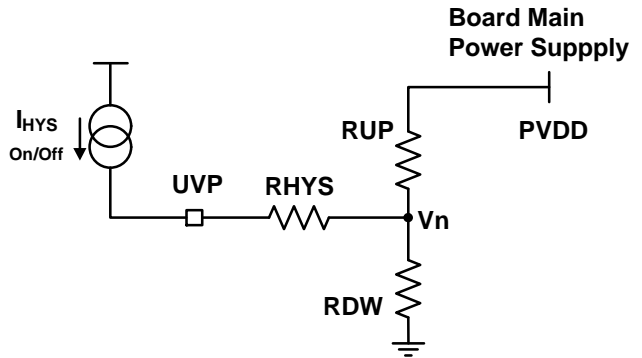

Figure 21. Voltage Divider Connected to UVP for Power Supply Monitoring

GAIN SETTING RESISTOR SELECTION (R_{IN} and R_{FB})

R_{IN} and R_{FB} set the closed-loop gain of the amplifier. The resistor values have to be chosen so that amplifier stability is preserved. A low gain configuration (close to 1) minimizes the THD + noise values and maximizes the signal to noise ratio.

A closed-loop gain in the range of 1 to 10 is recommended to optimize overall system performance.

Selecting values that are too low requires a relatively large input ac-coupling capacitor, C_{IN} . Selecting values that are too high increases the overall noise of the amplifier.

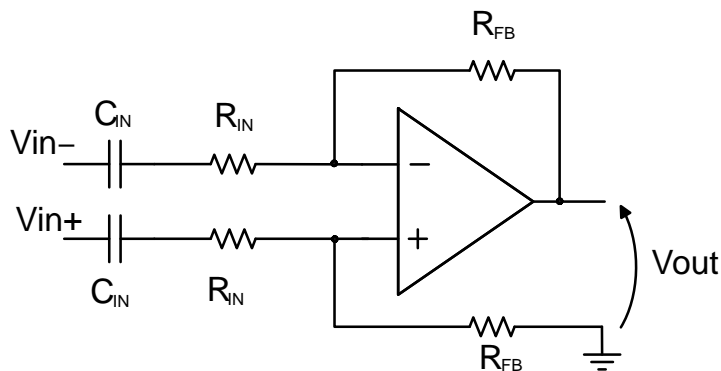

$$A_v = \frac{V_{out}}{V_{in+} - V_{in-}} = \frac{R_{FB}}{R_{in}} \quad (\text{eq. 9})$$

Figure 22. Differential Input Gain Configuration

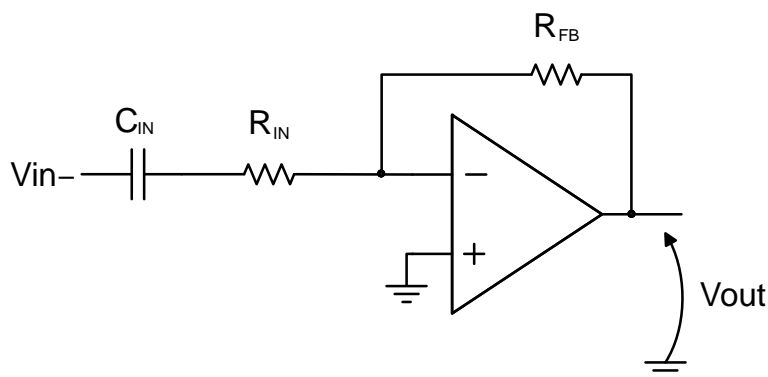

$$A_v = \frac{V_{out}}{V_{in-}} = -\frac{R_{FB}}{R_{IN}} \quad (\text{eq. 10})$$

Figure 23. Inverting Gain Configuration

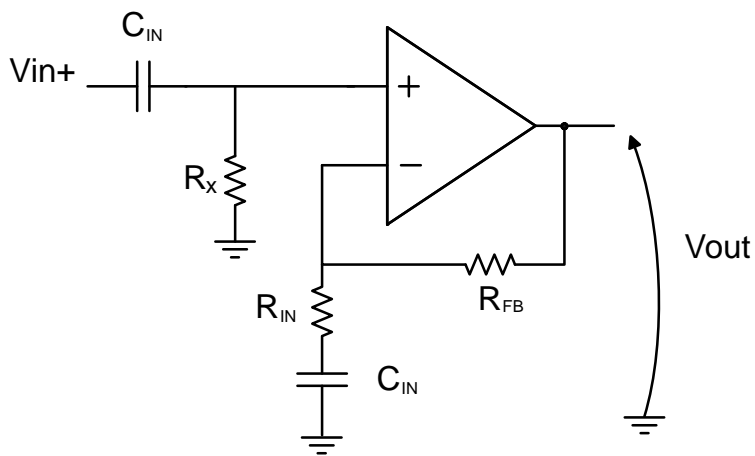

$$A_v = \frac{V_{out}}{V_{in+}} = 1 + \frac{R_{FB}}{R_{IN}} \quad (\text{eq. 11})$$

Figure 24. Non-Inverting Gain Configuration





onsemi

onsemi

onsemi

onsemi

— — — — —
— onsemi —
— onsemi —

onsemi

onsemi

onsemi

