



The NIS5132 is a cost effective, resettable fuse which can greatly enhance the reliability of a hard drive or other circuit from both catastrophic and shutdown failures.

It is designed to buffer the load device from excessive input voltage which can damage sensitive circuits. It also includes an overvoltage clamp circuit that limits the output voltage during transients but does not shut the unit down, thereby allowing the load circuit to continue operation. Two thermal options are available, latching and auto-retry.

- Integrated Power Device
- Power Device Thermally Protected
- No External Current Shunt Required
- 9 V to 18 V Input Range
- 44 mΩ Typical
- Internal Charge Pump
- Internal Undervoltage Lockout Circuit
- Internal Overvoltage Clamp (MN1 and MN2 versions)
- ESD Ratings: Human Body Model (HBM); 2000 V  
Machine Model (MM); 200 V
- These Devices are Pb-Free and are RoHS Compliant

- Hard Drives
- Mother Board Power Management

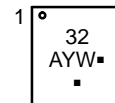

Pin	Function
1	GND
2	dv/dt
3	Enable/Fault
4	ILIMIT
5	NC
6-10	SOURCE
11 (flag)	VCC

32 = Latching Version with  $V_{Clamp}$   
 32B = Latching Version without  $V_{Clamp}$   
 32H = Auto-Retry Version with  $V_{Clamp}$   
 A = Assembly Location  
 Y = Year  
 W = Work Week  
 ■ = Pb-Free Package

(Note: Microdot may be in either location)

See detailed ordering and shipping information in the ordering information section on page 10 of this data sheet.

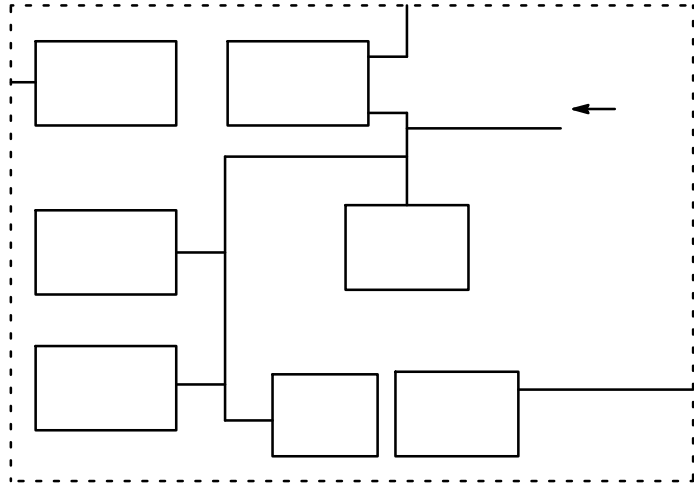

(Unless otherwise noted:  $V_{CC} = 12\text{ V}$ ,  $C_L = 100\ \mu\text{F}$ ,  $dv/dt$  pin open,  $R_{LIMIT} = 10\ \Omega$ ,  $T_j = 25^\circ\text{C}$

unless otherwise noted.)

--	--	--	--	--	--

Delay Time (enabling of chip to $I_D = 100\text{ mA}$ with 1 A resistive load)	$T_{dly}$		220		$\mu\text{s}$
Kelvin ON Resistance (Note 4) $T_j = 140^\circ\text{C}$ (Note 5)	$R_{DSon}$	35	44 62	55	$\text{m}\Omega$
Off State Output Voltage ( $V_{CC} = 18\text{ V}_{dc}$ , $V_{GS} = 0\text{ V}_{dc}$ , $R_L = \quad$ )	$V_{off}$		190	300	$\text{mV}$
Output Capacitance ( $V_{DS} = 12\text{ V}_{dc}$ , $V_{GS} = 0\text{ V}_{dc}$ , $f = 1\text{ MHz}$ )			250		$\text{pF}$
Continuous Current ( $T_A = 25^\circ\text{C}$ , 0.5 in <sup>2</sup> pad) (Note 5) ( $T_A = 80^\circ\text{C}$ , minimum copper)	$I_D$ $I_D$		3.6 1.7		A

Shutdown Temperature (Note 5)	$T_{SD}$	150	175	200	$^\circ\text{C}$
Thermal Hysteresis (Decrease in die temperature for turn on, does not apply to latching parts)	$T_{Hyst}$		45		$^\circ\text{C}$

Output Clamping Voltage (Overvoltage Protection) ( $V_{CC} = 18\text{ V}$ ) (Note 6)	$V_{Clamp}$	14	15	16.2	V
Undervoltage Lockout (Turn on, voltage going high)	$V_{UVLO}$	7.7	8.5	9.3	V
UVLO Hysteresis	$V_{Hyst}$	–	0.80	–	V

Kelvin Short Circuit Current Limit ( $R_{Limit} = 15.4\ \Omega$ , Note 7)	$I_{Lim-SS}$	2.75	3.44	4.25	A
Kelvin Overload Current Limit ( $R_{Limit} = 15.4\ \Omega$ , Note 7)	$I_{Lim-OL}$		4.6		A

Output Voltage Ramp Time (Enable to $V_{OUT} = 11.7\text{ V}$ )	$t_{slew}$	0.5	0.9	1.8	ms
Maximum Capacitor Voltage	$V_{max}$			$V_{CC}$	V

Logic Level Low (Output Disabled)	$V_{in-low}$	0.35	0.58	0.81	V
Logic Level Mid (Thermal Fault, Output Disabled)	$V_{in-mid}$	0.82	1.4	1.95	V
Logic Level High (Output Enabled)	$V_{in-high}$	1.96	2.64	3.30	V
High State Maximum Voltage	$V_{in-max}$	3.40	4.30	5.2	V
Logic Low Sink Current ( $V_{enable} = 0\text{ V}$ )	$I_{in-low}$		–17	–25	$\mu\text{A}$
Logic High Leakage Current for External Switch ( $V_{enable} = 3.3\text{ V}$ )	$I_{in-leak}$			1.0	$\mu\text{A}$
Maximum Fanout for Fault Signal (Total number of chips that can be connected to this pin for simultaneous shutdown)	Fan			3.0	Units

Bias Current (Operational)	$I_{Bias}$		1.8	2.5	mA
Bias Current (Shutdown)	$I_{Bias}$		1.0		mA
Minimum Operating Voltage (Notes 5 and 8)	$V_{min}$			7.6	V

Product parametric performance is indicated in the Electrical Characteristics for the listed test conditions, unless otherwise noted. Product

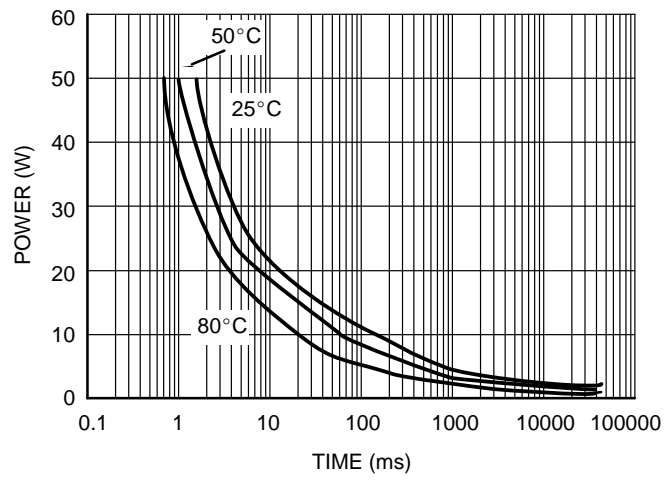

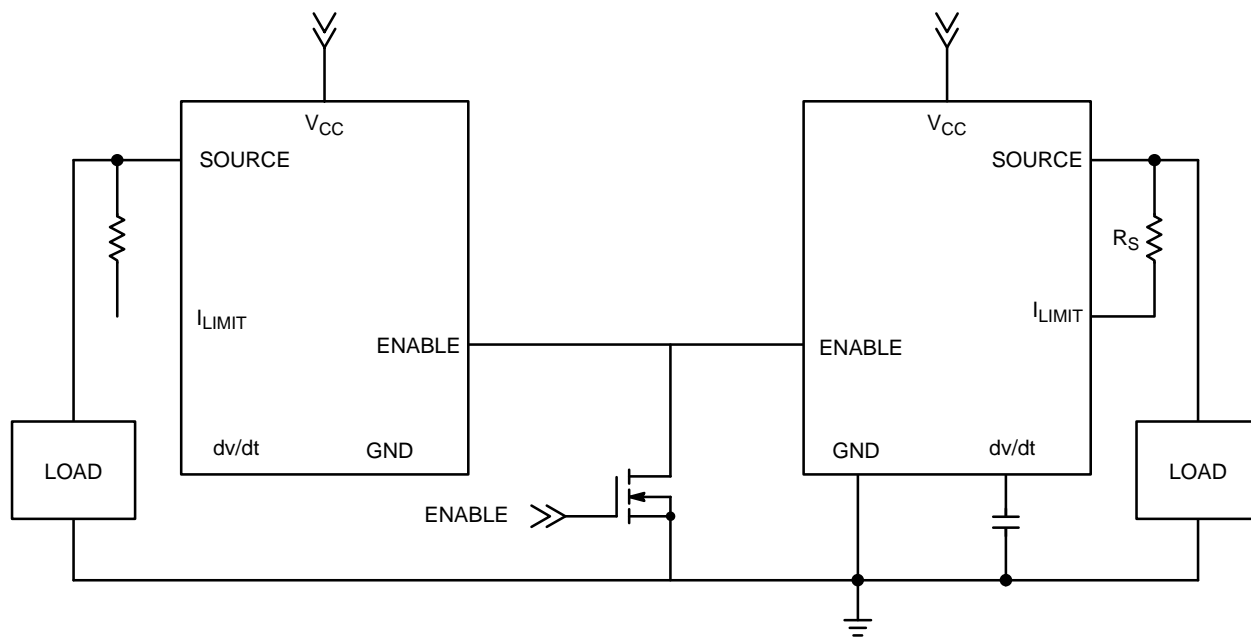

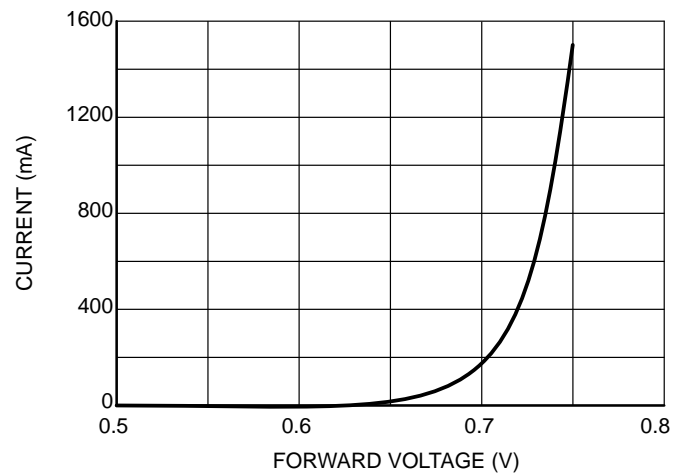
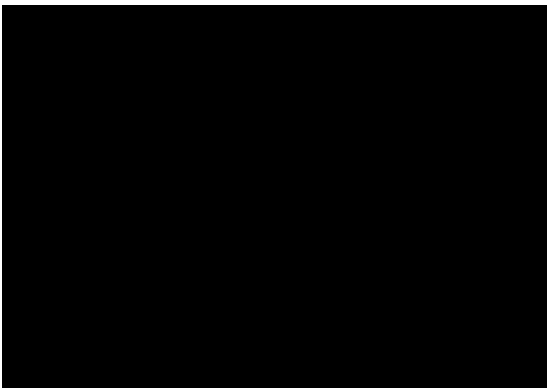
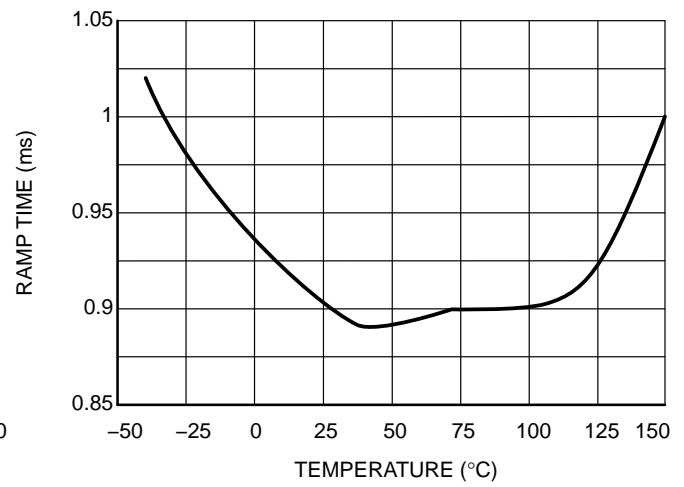
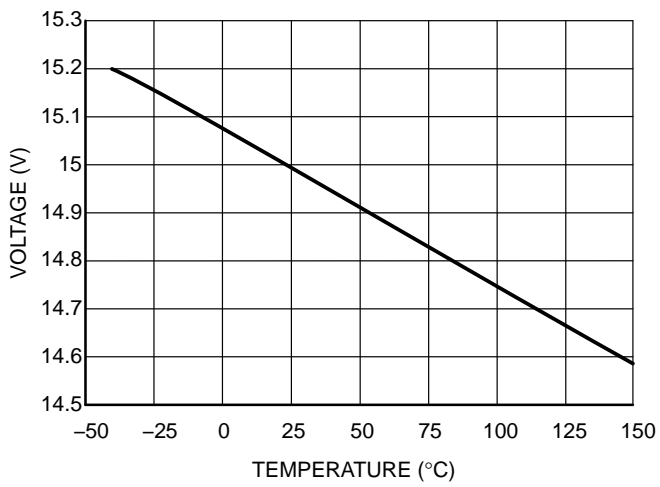
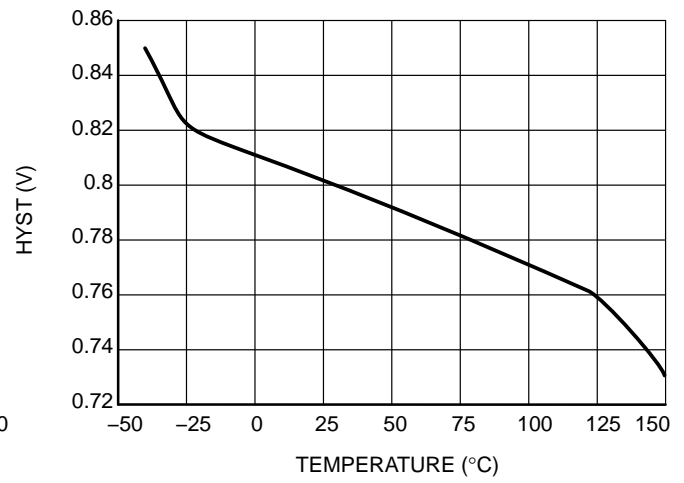
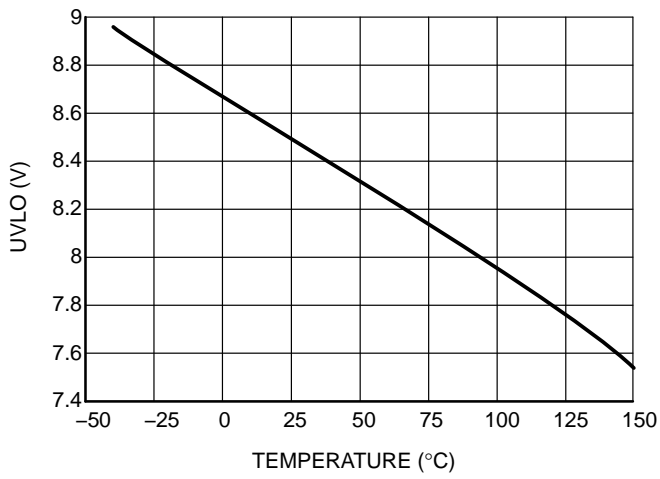

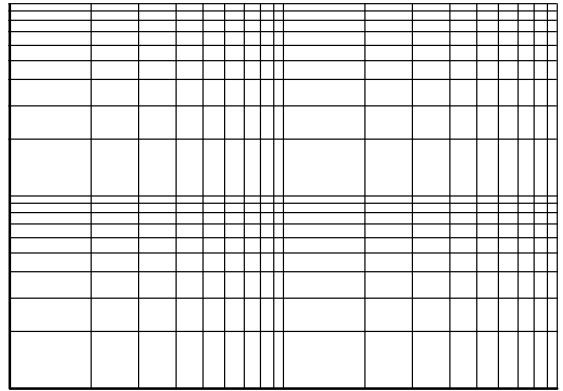
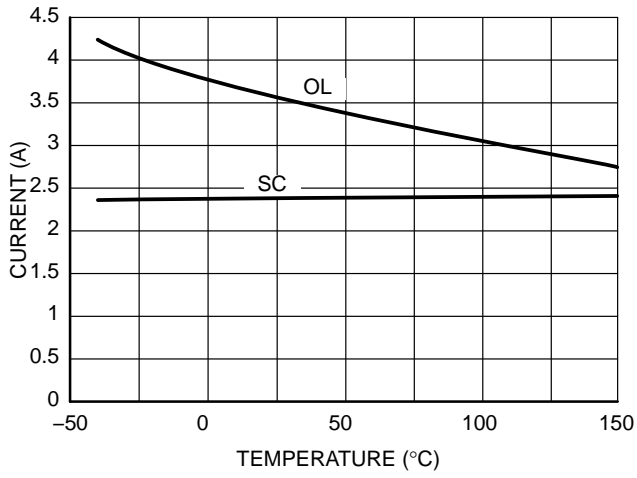
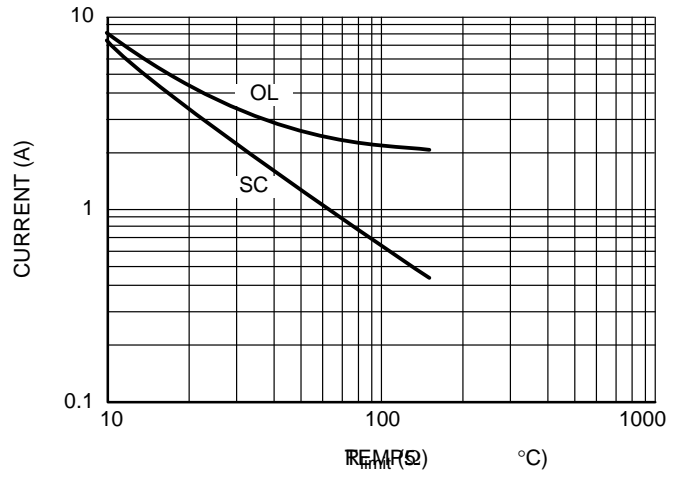
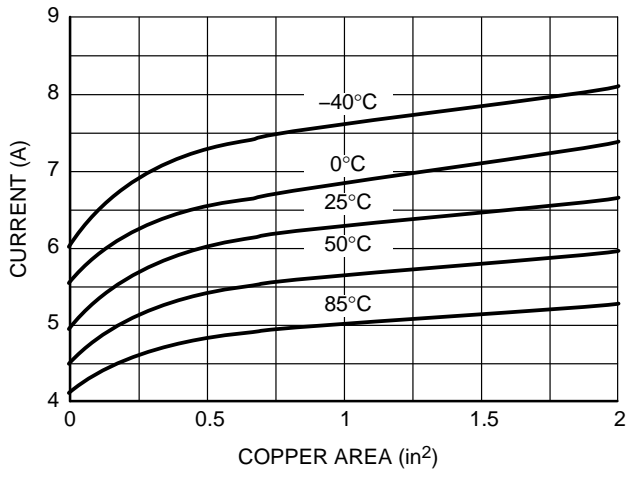

$\Omega$

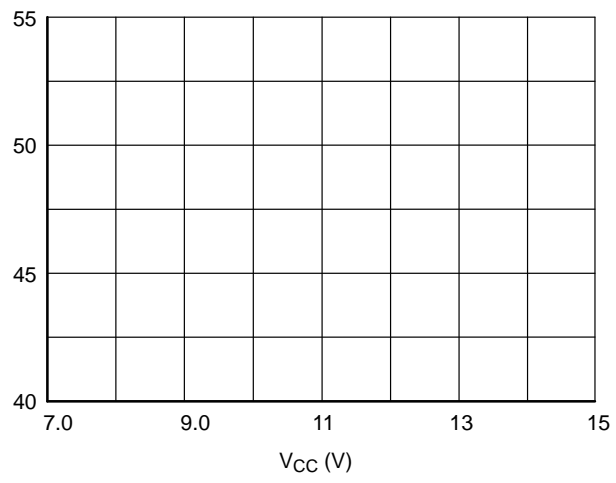



The undervoltage lockout circuit uses a comparator with hysteresis to monitor the input voltage. If the input voltage drops below the specified level, the output switch will be switched to a high impedance state.

The dv/dt circuit brings the output voltage up under a linear, controlled rate regardless of the load impedance characteristics. An internal ramp generator creates a linear ramp, and a control circuit forces the output voltage to follow that ramp, scaled by a factor.

The default ramp time is approximately 2 ms. This can be modified by adding an external capacitor at the dv/dt pin. This pin includes an internal current source of approximately 85 nA. Since the current level is very low, it is important to use a ceramic cap or other low leakage capacitor. Aluminum electrolytic capacitors are not recommended for this circuit.

The ramp time from 0 to the nominal output voltage can be determined by the following equation, where  $t$  is in seconds:

$$t_0 = 12 \cdot 24e6 \cdot 50 \text{ pF} \cdot C_{\text{ext}}$$







**onsemi**, **onsemi**, and other names, marks, and brands are registered and/or common law trademarks of Semiconductor Components Industries, LLC dba "**onsemi**" or its affiliates and/or subsidiaries in the United States and/or other countries. **onsemi** owns the rights to a number of patents, trademarks, copyrights, trade secrets, and other intellectual property. A listing of **onsemi**'s product/patent coverage may be accessed at [www.onsemi.com/site/pdf/Patent-Marking.pdf](http://www.onsemi.com/site/pdf/Patent-Marking.pdf). **onsemi** reserves the right to make changes at any time to any products or information herein, without notice. The information herein is provided "as-is" and **onsemi** makes no warranty, representation or guarantee regarding the accuracy of the information, product features, availability, functionality, or suitability of its products for any particular purpose, nor does **onsemi** assume any liability arising out of the application or use of any product or circuit, and specifically disclaims any and all liability, including without limitation special, consequential or incidental damages. Buyer is responsible for its products and applications using **onsemi**

---

---