

4-Bit 140 Mb/s Configurable Dual-Supply Bidirectional Level Translator

NL3X5004, NL3XN5004

The NL3X5004 and NL3XN5004 are 4-bit configurable dual-supply autosensing bidirectional level translators that do not require direction control pins. The A- and B-ports are designed to track two different power supply rails, V_{CCA} and V_{CCB} respectively. Both the V_{CCA} and the V_{CCB} supply rails are independently configurable from 0.9 V to 3.6 V.

The NL3X5004 and NL3XN5004 have high dynamic output current capability, allowing the translators to drive high capacitive loads.

Enable input pins are available to reduce the power consumption. These pins may be used to disable both A- and B-ports by putting them in 3-state significantly reducing the supply current from both V_{CCA} and V_{CCB} . These pins are referenced to the V_{CCA} supply. The NL3X5004 has an active-High enable (EN) while the NL3XN5004 has active-Low enable (\overline{EN}).

Features

- Wide V_{CCA} , V_{CCB} Operating Range: 0.9 V to 3.6 V
- V_{CCA} and V_{CCB} are independent
 - V_{CCA} may be greater than, equal to, or less than V_{CCB}
- High 100 pF Capacitive Drive Capability
- High-Speed w/ 140 Mbps Guaranteed Data Rate for V_{CCA} , $V_{CCB} > 1.8$ V
- Low Bit-to-Bit skew
- Overvoltage Tolerant Enable and I/O Pins
- Non-preferential Power-Up Sequencing
- Partial Power-Off Protection
-

NL3X5004, NL3XN5004

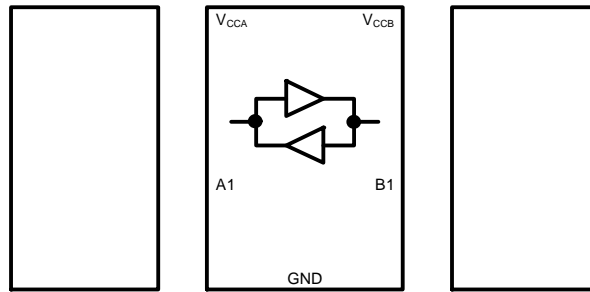

Figure 1. Typical Application Circuit

NL3X5004, NL3XN5004

PIN ASSIGNMENTS

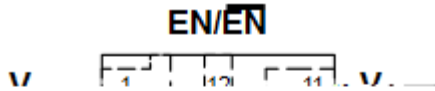

Figure 4. UQFN12

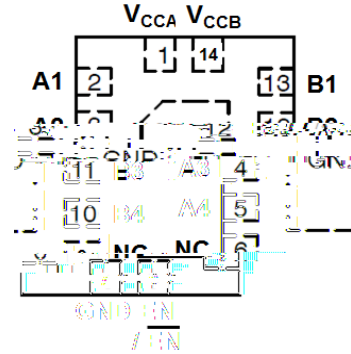

Figure 5. QFN14 (2.5 x 3.0)

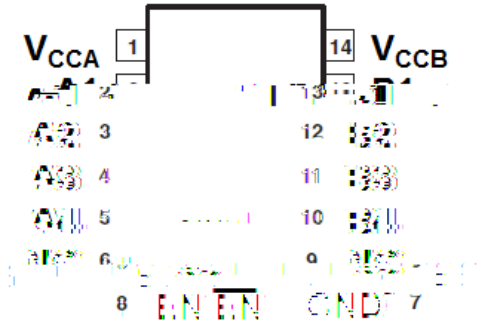

Figure 6. TSSOP / SOIC

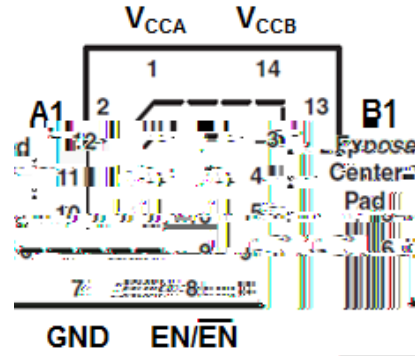

Figure 7. QFN14 (3.5 x 3.5)

PIN DESCRIPTIONS

Pins	Description
V _{CCA}	A-Port Supply Voltage
V _{CCB}	B-Port Supply Voltage
GND	Ground
EN	Active-High Enable (NL3X500n), Referenced to V _{CCA}
$\overline{\text{EN}}$	Active-Low Enable (NL3XN500n), Referenced to V _{CCA}
A _n	A-Port, Referenced to V _{CCA}
B _n	B-Port, Referenced to V _{CCB}

NL3X5004, NL3XN5004

Table 1. MAXIMUM RATINGS

Symbol	Parameter	Value	Condition	Unit
V_{CCA}	A-side DC Supply Voltage	-0.5 to +4.3		V
V_{CCB}	B-side DC Supply Voltage	-0.5 to +4.3		V
V_{IN}	Input/Output Voltage EN/\overline{EN}	-0.5 to +4.3		V
	Power Down Mode (V_{CCA} and/or $V_{CCB} = 0$ V)		-0.5 to +4.3	
	Tri-State Mode ($EN = L$ or $\overline{EN} = H$)		-0.5 to +4.3	
	Active Mode	A-Port	-0.5 to $V_{CCA}+0.5$	
		B-Port	-0.5 to $V_{CCB}+0.5$	
I_{IK}	DC Input Diode Current	-50	$V_{IN} < GND$	mA
I_{OK}	DC Output Diode Current	-50	$V_O < GND$	mA
I_{CCA}	DC Supply Current Through V_{CCA}	± 100		mA
I_{CCB}	DC Supply Current Through V_{CCB}	± 100		mA
I_{GND}	DC Ground Current Through Ground Pin	± 100		mA
T_{STG}	Storage Temperature	-65 to +150		$^{\circ}C$
θ_{JA}	Thermal Resistance (Note 1)	UQFN12	143	$^{\circ}C/W$
		SOIC-14	116	
		QFN14	130	
		TSSOP14	150	
P_D	Power Dissipation in Still Air	UQFN12	875	mW
		SOIC-14	1077	
		QFN14	962	
		TSSOP14	833	

Stresses exceeding those listed in the Maximum Ratings table may damage the device. If any of these limits are exceeded, device functionality should not be assumed, damage may occur and reliability may be affected.

1. Measured with minimum pad spacing on an FR4 board, using 76mm-by-114mm, 2-ounce copper trace no air flow per JESD51-7.

Table 2. RECOMMENDED OPERATING CONDITIONS

Symbol	Parameter	Min	Max	Unit	
V_{CCA}	A-Port Supply Voltage	0.9	3.6	V	
V_{CCB}	B-Port Supply Voltage	0.9	3.6	V	
V_I	Input/Output Voltage EN/\overline{EN}	GND	3.6	V	
	Power Down Mode (V_{CCA} and/or $V_{CCB} = 0$ V)		GND		3.6
	Tri-State Mode ($EN = L$ or $\overline{EN} = H$)		GND		3.6
	Active Mode	A-Port	GND		V_{CCA}
		B-Port	GND	V_{CCB}	
T_A	Operating Temperature Range	-40	+125	$^{\circ}C$	
$\Delta t/\Delta V$	Input Transition Rise or Fall Rate V_I from 30% to 70% of V_{CCA}/V_{CCB}	0	10	ns/V	

Functional operation above the stresses listed in the Recommended Operating Ranges is not implied. Extended exposure to stresses beyond the Recommended Operating Ranges limits may affect device reliability.

NL3X5004, NL3XN5004



NL3X5004, NL3XN5004

Table 4. TIMING CHARACTERISTICS

Symbol	Parameter	Test Conditions	V _{CCA} (V)	V _{CCB} (V)	-40°C to +85°C	-40°C to +125

V _{CCB} (V)	-40°C to +85°C			-40°C to +125°C		Unit
	Min	Typ (Note 4)	Max	Min	Max	
3.3	-	4.2	6.5	-	6.5	ns
1.8	-	6.1	7.4	-	7.4	
1.8 – 3.6	-	4.5	10	-	10.5	

NL3X5004, NL3XN5004

Table 4. TIMING CHARACTERISTICS (continued)

Symbol	Parameter	Test Conditions	V _{CCA} (V)	V _{CCB} (V)	-40°C to +85°C			-40°C to +125°C		Unit
					Min	Typ (Note 4)	Max	Min	Max	
t _{SK}	Channel-to-Channel Skew		0.9 – 3.6	0.9 – 3.6	–	0.15	–	–	–	ns
MDR	Maximum Data Rate	C _L = 15 pF	0.9 – 3.6	0.9 – 3.6	–	50	–	–	–	Mbps
			1.1 – 3.6	1.1 – 3.6	50	–	–	50	–	
			1.8 – 3.6	1.8 – 3.6	140	–	–	140	–	
		C _L = 30 pF	0.9 – 3.6	0.9 – 3.6	–	40	–	–	–	
			1.1 – 3.6	1.1 – 3.6	40	–	–	40	–	
			1.8 – 3.6	1.8 – 3.6	120	–	–	120	–	
		C _L = 50 pF	0.9 – 3.6	0.9 – 3.6	–	30	–	–	–	
			1.1 – 3.6	1.1 – 3.6	30	–	–	30	–	
			1.8 – 3.6	1.8 – 3.6	100	–	–	100	–	
		C _L = 100 pF	0.9 – 3.6	0.9 – 3.6	–	20	–	–	–	
			1.1 – 3.6	1.1 – 3.6	20	–	–	20	–	
			1.8 – 3.6	1.8 – 3.6	60	–	–	60	–	

NL3X5004, NL3XN5004

Table 4. TIMING CHARACTERISTICS (continued)

Symbol	Parameter	Test Conditions		V _{CCA} (V)	V _{CCB} (V)	-40°C to +85°C			-40°C to +125°C		Unit
						Min	Typ (Note 4)	Max	Min	Max	
t _{EN}	Output Enable Time	C _L = 15 pF; B = V _{CCB}	EN/ $\overline{\text{EN}}$ to A	0.9 – 3.6	0.9 – 3.6	–	125	–	–	–	ns
				1.1 – 3.6	1.1 – 3.6	–	116.3	200	–	200	
				1.2 – 1.8	1.2 – 1.8	–	64.5	180	–	180	
				1.8 – 2.8	1.8 – 2.8	–	49.6	150	–	150	
				1.8 – 3.6	1.8 – 3.6	–	42.5	100	–	100	
		C _L = 15 pF; B = 0 V	0.9 – 3.6	0.9 – 3.6	–	205	–	–	–		

NL3X5004, NL3XN5004

Table 4. TIMING CHARACTERISTICS (continued)

Symbol	Parameter	Test Conditions	V _{CCA} (V)	V _{CCB} (V)	-40°C to +85°C			-40°C to +125°C		Unit	
					Min	Typ (Note 4)	Max	Min	Max		
t _{DIS}	Output Disable Time	C _L = 15 pF; B = V _{CCB}	EN/ $\overline{\text{EN}}$ to A	0.9 – 3.6	0.9 – 3.6	–	270	–	–	–	ns
				1.1 – 3.6	1.1 – 3.6	–	255	600	–	600	
				1.2 – 1.8	1.2 – 1.8	–	180	350	–	350	
				1.8 – 2.8	1.8 – 2.8	–	166.7	350	–	–	

NL3X5004, NL3XN5004

Table 4. TIMING CHARACTERISTICS (continued)

Symbol	Parameter	Test Conditions	V _{CCA} (V)	V _{CCB} (V)	-40°C to +85°C			-40°C to +125°C		Unit	
					Min	Typ (Note 4)	Max	Min	Max		
Z _O (Note 4)	1-Shot Output Impedance		A	0.9 – 3.6	0.9 – 3.6	–	55	–	–	–	Ω
				1.1	1.1 – 3.6	–	37	–	–	–	
				1.8		–	20	–	–	–	
				3.6		–	10	–	–	–	
			B	0.9 – 3.6	0.9 – 3.6	–	55	–	–	–	
				1.1 – 3.6	1.1	–	37	–	–	–	
					1.8	–	20	–	–	–	
					3.6	–	10	–	–	–	

4. Typical values are for T_A = +25°C.

NL3X5004, NL3XN5004

IMPORTANT APPLICATIONS INFORMATION

Level Translator Architecture

The NL3X5004 and the NL3XN5004 auto-sense translators provide bi-directional logic voltage level shifting to transfer data in multiple supply voltage systems. These level translators have two supply voltages, V_{CCA} and V_{CCB} , which set the logic levels on the input and output sides of the translator. When used to transfer data from the A to the B ports, input signals referenced to the V_{CCA} supply are translated to output signals with a logic level matched to V_{CCB} . In a similar manner, the B to A translation shifts input signals with a logic level compatible to V_{CCB} to an output signal matched to V_{CCA} .

The NL3X5004 and the NL3XN5004 translators consist of bi-directional channels that independently determine the direction of the data flow without requiring a directional pin. One-shot circuits are used to detect the rising or falling input signals. In addition, the one-shots decrease the rise and fall times of the output signal for

NL3X5004, NL3XN5004

DEVICE ORDERING INFORMATION

Device Order Number	Device Marking	Package Type	Tape & Reel Size†
NL3X5004MU2TAG	AA2	UQFN-12, 1.7 x 2.0	3000 / Tape & Reel
NL3X5004MU2TAG-Q*	AA2	UQFN-12, 1.7 x 2.0	3000 / Tape & Reel
NL3X5004MN1TXG	V4		

NL3X5004, NL3XN5004

PACKAGE DIMENSIONS

UQFN12 1.7x2.0, 0.4P
CASE 523AE
ISSUE A

NOTES:

1. DIMENSIONING AND TOLERANCING PER ASME Y14.5M, 1994.
2. CONTROLLING DIMENSION: MILLIMETERS
3. DIMENSION b APPLIES TO PLATED TERMINAL AND IS MEASURED BETWEEN 0.15 AND 0.30 MM FROM TERMINAL TIP.
4. MOLD FLASH ALLOWED ON TERMINALS

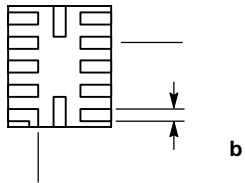
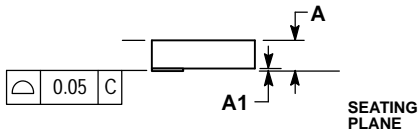
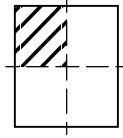

NOTE 3

NL3X5004, NL3XN5004

PACKAGE DIMENSIONS

SOIC-14 NB
CASE 751A-03
ISSUE L

NOTES:

NL3X5004, NL3XN5004

PACKAGE DIMENSIONS

TSSOP-14 WB
CASE 948G
ISSUE C

NOTES:

1. DIMENSIONING AND TOLERANCING PER ANSI Y14.5M, 1982.
2. CONTROLLING DIMENSION: MILLIMETER.
3. DIMENSION A DOES NOT INCLUDE MOLD FLASH, PROTRUSIONS OR GATE BURRS. MOLD FLASH OR GATE BURRS SHALL NOT EXCEED 0.15 (0.006) PER SIDE.
4. DIMENSION B DOES NOT INCLUDE INTERLEAD FLASH OR PROTRUSION. INTERLEAD FLASH OR PROTRUSION SHALL NOT EXCEED 0.25 (0.010) PER SIDE.
5. DIMENSION K DOES NOT INCLUDE DAMBAR PROTRUSION. ALLOWABLE DAMBAR PROTRUSION SHALL BE 0.08 (0.003) TOTAL IN EXCESS OF THE K DIMENSION AT MAXIMUM MATERIAL CONDITION.
6. TERMINAL NUMBERS ARE SHOWN FOR REFERENCE ONLY.
7. DIMENSION A AND B ARE TO BE DETERMINED AT DATUM PLANE -W-.

DIM	MILLIMETERS		INCHES	
	MIN	MAX	MIN	MAX
A	4.90	5.10	0.193	0.200
B	4.30	4.50	0.169	0.177
C	---	1.20	---	0.047
D	0.05	0.15	0.002	0.006
F	0.50	0.75	0.020	0.030
G	0.65	BSC	0.026	BSC
H	0.50	0.60	0.020	0.024
J	0.09	0.20	0.004	0.008
J1	0.09	0.16	0.004	0.006
K	0.19	0.30	0.007	0.012
K1	0.19	0.25	0.007	0.010
L	6.40	BSC	0.252	BSC
M	0 °	8 °	0 °	8 °

NL3X5004, NL3XN5004

PACKAGE DIMENSIONS

QFN14, 2.5x3.0, 0.5P
CASE 485DE
ISSUE O

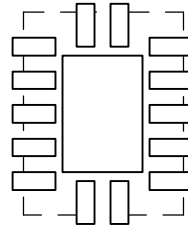

NL3X5004, NL3XN5004

PACKAGE DIMENSIONS

QFN14 3.5x3.5, 0.5P
CASE 485AL
ISSUE O

NOTES:

