

AXIAL LEAD
CASE 017AF
ISSUE 0

DATE 31 AUG 2016

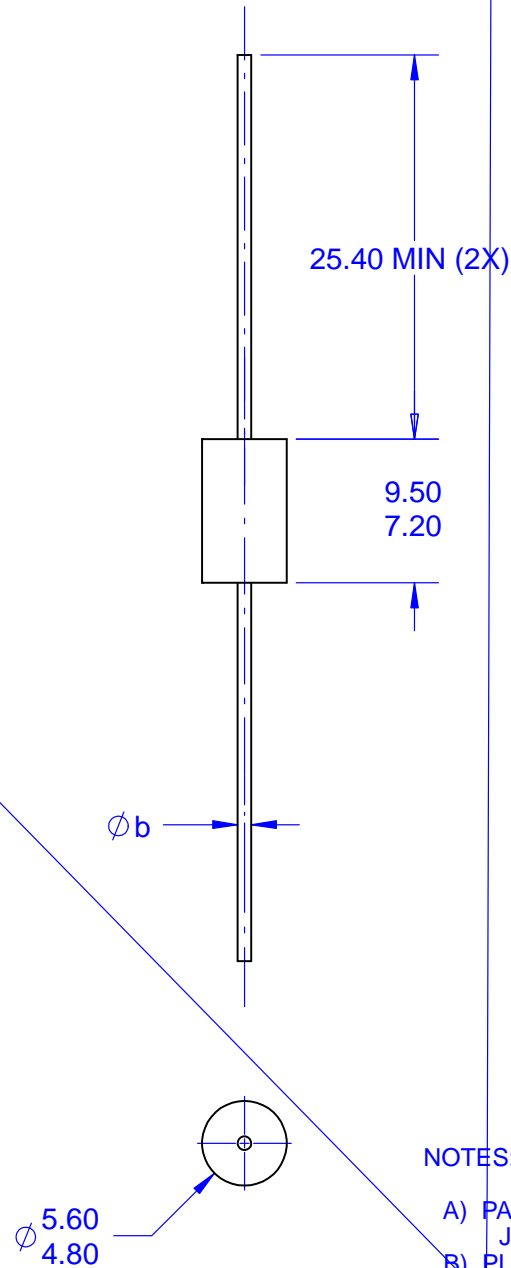

NOTES: UNLESS OTHERWISE SPECIFIED

- A) PACKAGE STANDARD REFERENCE:
JEDEC DO-201 VARIATION AD.
- B) PLASTIC PACKAGE BODY.
- C) ALL DIMENSIONS ARE IN MILLIMETERS.
- D) ϕb DIMENSION REPRESENT LIKE BELOW:
OPTION AD = 1.20MIN TO 1.30MAX
OPTION AE = 0.94MIN TO 1.07MAX