

- -
CASE 340AB
ISSUE A

DATE 30 OCT 2007

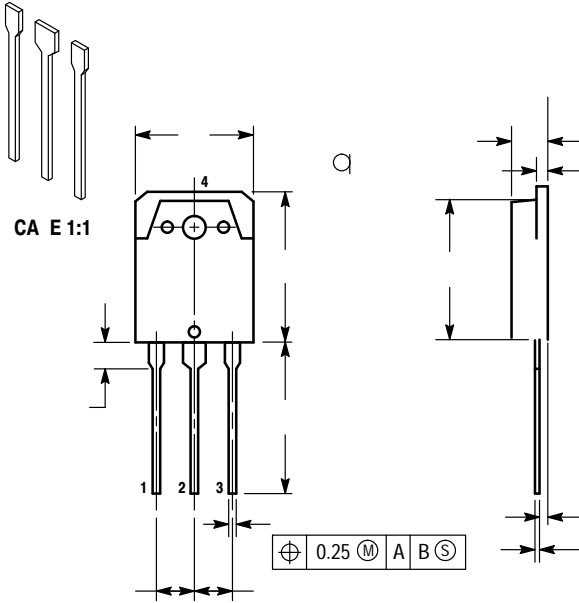

NOTES:

1. DIMENSIONING AND TOLERANCING PER ASME Y14.5M, 1994.
2. CONTROLLING DIMENSION: MILLIMETERS
3. DIMENSION b APPLIES TO PLATED TERMINAL AND IS MEASURED BETWEEN 0.15 AND 0.30mm FROM THE TERMINAL TIP.
4. DIMENSION A AND B DO NOT INCLUDE MOLD FLASH, PROTRUSIONS, OR GATE BURRS.

D	E E		
			A ₂
A	19.70	19.90	20.10
B	15.40	15.60	15.80
C	4.60	4.80	5.00
D	0.80	1.00	1.20
E	1.45	1.50	1.65
F	1.80	2.00	2.20
G	5.45 BSC		
	1.20	1.40	1.60
	0.55	0.60	0.75
K	19.80	20.00	20.20
	18.50	18.70	18.90
	3.30	3.50	3.70
	3.10	3.20	3.50
	5.00 REF		
	2.80	3.00	3.20